

(19) World Intellectual Property Organization
International Bureau



(43) International Publication Date
10 September 2010 (10.09.2010)

PCT

(10) International Publication Number
WO 2010/100461 A1

- (51) **International Patent Classification:**
F24F 13/32 (2006.01) *F04D 25/10* (2006.01)
- (21) **International Application Number:**
PCT/GB2010/050282
- (22) **International Filing Date:**
18 February 2010 (18.02.2010)
- (25) **Filing Language:** English
- (26) **Publication Language:** English
- (30) **Priority Data:**
0903670.8 4 March 2009 (04.03.2009) GB
- (71) **Applicant (for all designated States except US):** **DYSON TECHNOLOGY LIMITED** [GB/GB]; Tetbury Hill, Malmesbury Wiltshire SN16 0RP (GB).
- (72) **Inventors; and**
- (75) **Inventors/Applicants (for US only):** **GAMMACK, Peter** [GB/GB]; Dyson Technology Limited, Tetbury Hill, Malmesbury Wiltshire SN16 0RP (GB). **DYSON, James** [GB/GB]; Dyson Technology Limited, Tetbury Hill, Malmesbury Wiltshire SN16 0RP (GB).
- (74) **Agents:** **BOOTH, Andrew** et al.; Dyson Technology Limited, Intellectual Property Department, Tetbury Hill, Malmesbury, Wiltshire SN16 0RP (GB).

(81) **Designated States (unless otherwise indicated, for every kind of national protection available):** AE, AG, AL, AM, AO, AT, AU, AZ, BA, BB, BG, BH, BR, BW, BY, BZ, CA, CH, CL, CN, CO, CR, CU, CZ, DE, DK, DM, DO, DZ, EC, EE, EG, ES, FI, GB, GD, GE, GH, GM, GT, HN, HR, HU, ID, IL, IN, IS, JP, KE, KG, KM, KN, KP, KR, KZ, LA, LC, LK, LR, LS, LT, LU, LY, MA, MD, ME, MG, MK, MN, MW, MX, MY, MZ, NA, NG, NI, NO, NZ, OM, PE, PG, PH, PL, PT, RO, RS, RU, SC, SD, SE, SG, SK, SL, SM, ST, SV, SY, TH, TJ, TM, TN, TR, TT, TZ, UA, UG, US, UZ, VC, VN, ZA, ZM, ZW.

(84) **Designated States (unless otherwise indicated, for every kind of regional protection available):** ARIPO (BW, GH, GM, KE, LS, MW, MZ, NA, SD, SL, SZ, TZ, UG, ZM, ZW), Eurasian (AM, AZ, BY, KG, KZ, MD, RU, TJ, TM), European (AT, BE, BG, CH, CY, CZ, DE, DK, EE, ES, FI, FR, GB, GR, HR, HU, IE, IS, IT, LT, LU, LV, MC, MK, MT, NL, NO, PL, PT, RO, SE, SI, SK, SM, TR), OAPI (BF, BJ, CF, CG, CI, CM, GA, GN, GQ, GW, ML, MR, NE, SN, TD, TG).

Published:

- with international search report (Art. 21(3))
- before the expiration of the time limit for amending the claims and to be republished in the event of receipt of amendments (Rule 48.2(h))

(54) Title: A FAN ASSEMBLY

FIG. 1

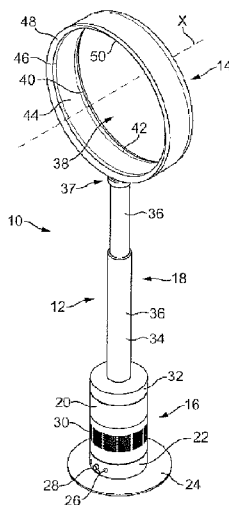

(57) **Abstract:** A fan assembly (10) comprises means (64, 68) for creating an air flow and an air outlet (14) for emitting the air flow, the air outlet (14) being mounted on a pedestal (12) comprising a base (16) and a height adjustable stand (18). The base (16) comprises means (56) for oscillating the stand (18) and the air outlet (14).

WO 2010/100461 A1

A Fan Assembly

The present invention relates to a fan assembly. In a preferred embodiment, the present invention relates to a domestic fan, such as a pedestal fan, for creating an air current in a room, office or other domestic environment.

A conventional domestic fan typically includes a set of blades or vanes mounted for rotation about an axis, and drive apparatus for rotating the set of blades to generate an air flow. The movement and circulation of the air flow creates a 'wind chill' or breeze and, as a result, the user experiences a cooling effect as heat is dissipated through convection and evaporation.

Such fans are available in a variety of sizes and shapes. For example, a ceiling fan can be at least 1 m in diameter, and is usually mounted in a suspended manner from the ceiling to provide a downward flow of air to cool a room. On the other hand, desk fans are often around 30 cm in diameter, and are usually free standing and portable. Floor-standing pedestal fans generally comprise a height adjustable pedestal supporting the drive apparatus and the set of blades for generating an air flow, usually in the range from 300 to 500 l/s. The pedestal may also support a mechanism for oscillating the drive apparatus and the set of blades to sweep the air flow over an arc.

A disadvantage of this type of arrangement is that the air flow produced by the rotating blades of the fan is generally not uniform. This is due to variations across the blade surface or across the outward facing surface of the fan. The extent of these variations can vary from product to product and even from one individual fan machine to another. These variations result in the generation of an uneven or 'choppy' air flow which can be felt as a series of pulses of air and which can be uncomfortable for a user.

In a domestic environment it is undesirable for parts of the appliance to project outwardly, or for a user to be able to touch any moving parts, such as the blades. Pedestal fans tend to have a cage surrounding the blades to prevent injury from contact

with the rotating blades, but such caged parts can be difficult to clean. Furthermore, due to the mounting of the drive apparatus and the rotary blades on the top of the pedestal, the centre of gravity of a pedestal fan is usually located towards the top of the pedestal. This can render the pedestal fan prone to falling if accidentally knocked
5 unless the pedestal is provided with a relatively wide or heavy base, which may be undesirable for a user.

The present invention provides a fan assembly comprising means for creating an air flow and an air outlet for emitting the air flow, the air outlet being mounted on a
10 pedestal housing said means for creating an air flow, the pedestal comprising a base and a height adjustable stand, the base comprising means for oscillating the stand, the air outlet and said means for creating an air flow.

As the oscillating means forms part of the base of the pedestal, the centre of gravity of
15 the fan assembly is lowered in comparison to prior art pedestal fans where the oscillating mechanism is supported by the pedestal. The oscillating means is preferably arranged to sweep the air flow emitted from the air outlet over an arc, which is preferably in the range from 60 to 120°.

20 Preferably, the base comprises an upper part and a lower part for engaging a floor surface, and wherein the oscillating means is arranged to oscillate the upper part of the base relative to the lower part of the base. The upper part of the base preferably houses said means for creating an air flow. This can further lower the centre of gravity of the fan assembly in comparison to prior art pedestal fans where a bladed fan and drive
25 apparatus for the bladed fan are connected to the top of the pedestal and thereby rendering the fan assembly less prone to falling over if knocked.

The upper part of the base preferably comprises a shaft extending into the lower portion of the base, with the lower portion of the base preferably comprising a sleeve for
30 receiving the shaft. The shaft is preferably rotatably supported with the sleeve by at least one bearing. The upper part of the base preferably comprises an annular connector

for connecting the shaft to a bottom surface of the upper part of the base. Preferably, the oscillating mechanism comprises a crank mechanism for oscillating the upper portion of the base relative to the lower portion of the base.

- 5 The stand preferably comprises, or is in the form of, a duct for conveying the air flow to the air outlet. Thus, the stand may serve to both support the air outlet through which an air flow created by the fan assembly is emitted and convey the created air flow to the nozzle. Preferably the means for creating an air flow through the nozzle comprises an impeller, a motor for rotating the impeller, and a diffuser located downstream from the
- 10 impeller. The impeller is preferably a mixed flow impeller. The motor is preferably a DC brushless motor to avoid frictional losses and carbon debris from the brushes used in a traditional brushed motor. Reducing carbon debris and emissions is advantageous in a clean or pollutant sensitive environment such as a hospital or around those with allergies. While induction motors, which are generally used in pedestal fans, also have
- 15 no brushes, a DC brushless motor can provide a much wider range of operating speeds than an induction motor.

The diffuser may comprise a plurality of spiral vanes, resulting in the emission of a spiraling air flow from the diffuser. As the air flow through the duct will generally be

20 in an axial or longitudinal direction, the fan assembly preferably comprises means for guiding the air flow emitted from the diffuser into the duct. This can reduce conductance losses within the fan assembly. The air flow guiding means preferably comprises a plurality of vanes each for guiding a respective portion of the air flow emitted from the diffuser towards the duct. These vanes may be located on the internal

25 surface of an air guiding member mounted over the diffuser, and are preferably substantially evenly spaced. The air flow guiding means may also comprise a plurality of radial vanes located at least partially within the duct, with each of the radial vanes adjoining a respective one of the plurality of vanes. These radial vanes may define a plurality of axial or longitudinal channels within the duct which each receive a

30 respective portion of the air flow from channels defined by the plurality of vanes. These portions of the air flow preferably merge together within the duct.

The duct may comprise a base mounted on the base of the pedestal, and a plurality of tubular members connected to the base of the duct. The curved vanes may be located at least partially within the base of the duct. The axial vanes may be located at least
5 partially within means for connecting one of the tubular members to the base of the duct. The connecting means may comprise an air pipe or other tubular member for receiving one of the tubular members.

The fan assembly is preferably in the form of a bladeless fan assembly. Through use of
10 a bladeless fan assembly an air current can be generated without the use of a bladed fan. In comparison to a bladed fan assembly, the bladeless fan assembly leads to a reduction in both moving parts and complexity. Furthermore, without the use of a bladed fan to project the air current from the fan assembly, a relatively uniform air current can be generated and guided into a room or towards a user. The air current can travel
15 efficiently out from the nozzle, losing little energy and velocity to turbulence.

The term 'bladeless' is used to describe a fan assembly in which air flow is emitted or projected forward from the fan assembly without the use of moving blades. Consequently, a bladeless fan assembly can be considered to have an output area, or
20 emission zone, absent moving blades from which the air flow is directed towards a user or into a room. The output area of the bladeless fan assembly may be supplied with a primary air flow generated by one of a variety of different sources, such as pumps, generators, motors or other fluid transfer devices, and which may include a rotating device such as a motor rotor and/or a bladed impeller for generating the air flow. The
25 generated primary air flow can pass from the room space or other environment outside the fan assembly through the telescopic duct to the nozzle, and then back out to the room space through the mouth of the nozzle.

Hence, the description of a fan assembly as bladeless is not intended to extend to the
30 description of the power source and components such as motors that are required for

secondary fan functions. Examples of secondary fan functions can include lighting, adjustment and oscillation of the fan assembly.

The shape of the fan assembly thus need not be constrained by the requirement to
5 include space for a bladed fan for projecting the air flow from the fan assembly. Preferably, the air outlet extends about, and preferably surrounds, an opening through which air from outside the fan assembly is drawn by the air flow emitted from the air outlet. The air outlet is preferably annular, and preferably has a height in the range from 200 to 600 mm, more preferably in the range from 250 to 500 mm.

10

Preferably, the air outlet comprises a nozzle comprising an interior passage for receiving the air flow from the duct and a mouth for emitting the air flow. Preferably, the mouth of the nozzle extends about the opening, and is preferably annular. The nozzle preferably comprises an inner casing section and an outer casing section which
15 define the mouth of the nozzle. Each section is preferably formed from a respective annular member, but each section may be provided by a plurality of members connected together or otherwise assembled to form that section. The outer casing section is preferably shaped so as to partially overlap the inner casing section. This can enable an outlet of the mouth to be defined between overlapping portions of the external surface
20 of the inner casing section and the internal surface of the outer casing section of the nozzle. The outlet is preferably in the form of a slot, preferably having a width in the range from 0.5 to 5 mm, more preferably in the range from 0.5 to 1.5 mm. The nozzle may comprise a plurality of spacers for urging apart the overlapping portions of the inner casing section and the outer casing section of the nozzle. This can assist in
25 maintaining a substantially uniform outlet width about the opening. The spacers are preferably evenly spaced along the outlet.

30

The nozzle preferably comprises an interior passage for receiving the air flow from the duct. The interior passage is preferably annular, and is preferably shaped to divide the air flow into two air streams which flow in opposite directions around the opening.

The interior passage is preferably also defined by the inner casing section and the outer casing section of the nozzle.

5 The maximum air flow of the air current generated by the fan assembly is preferably in the range from 300 to 800 litres per second, more preferably in the range from 500 to 800 litres per second.

10 The nozzle may comprise a surface located adjacent the mouth and over which the mouth is arranged to direct the air flow emitted therefrom. This surface is preferably a Coanda surface. Preferably, the external surface of the inner casing section of the nozzle is shaped to define the Coanda surface. The Coanda surface preferably extends about the opening. A Coanda surface is a type of surface over which fluid flow exiting an output orifice close to the surface exhibits the Coanda effect. The fluid tends to flow over the surface closely, almost 'clinging to' or 'hugging' the surface. The Coanda effect is already a proven, well documented method of entrainment in which a primary air flow is directed over a Coanda surface. A description of the features of a Coanda surface, and the effect of fluid flow over a Coanda surface, can be found in articles such as Reba, Scientific American, Volume 214, June 1966 pages 84 to 92. Through use of a Coanda surface, an increased amount of air from outside the fan assembly is drawn through the opening by the air emitted from the mouth.

25 In the preferred embodiment an air flow enters the nozzle of the fan assembly from the telescopic duct. In the following description this air flow will be referred to as primary air flow. The primary air flow is emitted from the mouth of the nozzle and preferably passes over a Coanda surface. The primary air flow entrains air surrounding the mouth of the nozzle, which acts as an air amplifier to supply both the primary air flow and the entrained air to the user. The entrained air will be referred to here as a secondary air flow. The secondary air flow is drawn from the room space, region or external environment surrounding the mouth of the nozzle and, by displacement, from other regions around the fan assembly, and passes predominantly through the opening defined by the nozzle. The primary air flow directed over the Coanda surface combined with

the entrained secondary air flow equates to a total air flow emitted or projected forward from the opening defined by the nozzle. Preferably, the entrainment of air surrounding the mouth of the nozzle is such that the primary air flow is amplified by at least five times, more preferably by at least ten times, while a smooth overall output is
5 maintained.

Preferably, the nozzle comprises a diffuser surface located downstream of the Coanda surface. The external surface of the inner casing section of the nozzle is preferably shaped to define the diffuser surface.

10

An embodiment of the present invention will now be described, by way of example only, with reference to the accompanying drawings, in which:

Figure 1 is a perspective view of a fan assembly, in which a telescopic duct of the fan
15 assembly is in a fully extended configuration;

Figure 2 is another perspective view of the fan assembly of Figure 1, in which the telescopic duct of the fan assembly is in a retracted position;

20 Figure 3 is a sectional view of the base of the pedestal of the fan assembly of Figure 1;

Figure 4 is an exploded view of the telescopic duct of the fan assembly of Figure 1;

Figure 5 is a side view of the duct of Figure 4 in a fully extended configuration;

25

Figure 6 is a sectional view of the duct taken along line A-A in Figure 5;

Figure 7 is a sectional view of the duct taken along line B-B in Figure 5;

30 Figure 8 is a perspective view of the duct of Figure 4 in a fully extended configuration, with part of the lower tubular member cut away;

Figure 9 is an enlarged view of part of Figure 8, with various parts of the duct removed;

Figure 10 is a side view of the duct of Figure 4 in a retracted configuration;

5

Figure 11 is a sectional view of the duct taken along line C-C in Figure 10;

Figure 12 is an exploded view of the nozzle of the fan assembly of Figure 1;

10 Figure 13 is a front view of the nozzle of Figure 12;

Figure 14 is a sectional view of the nozzle, taken along line P-P in Figure 13; and

Figure 15 is an enlarged view of area R indicated in Figure 14.

15

Figures 1 and 2 illustrate perspective views of an embodiment of a fan assembly 10. In this embodiment, the fan assembly 10 is a bladeless fan assembly, and is in the form of a domestic pedestal fan comprising a height adjustable pedestal 12 and a nozzle 14 mounted on the pedestal 12 for emitting air from the fan assembly 10. The pedestal 12 comprises a floor-standing base 16 and a height-adjustable stand in the form of a telescopic duct 18 extending upwardly from the base 16 for conveying a primary air flow from the base 16 to the nozzle 14.

20

The base 16 of the pedestal 12 comprises a substantially cylindrical motor casing portion 20 mounted on a substantially cylindrical lower casing portion 22. The motor casing portion 20 and the lower casing portion 22 preferably have substantially the same external diameter so that the external surface of the motor casing portion 20 is substantially flush with the external surface of the lower casing portion 22. The lower casing portion 22 is mounted optionally on a floor-standing, disc-shaped base plate 24, and comprises a plurality of user-operable buttons 26 and a user-operable dial 28 for controlling the operation of the fan assembly 10. The base 16 further comprises a

30

plurality of air inlets 30, which in this embodiment are in the form of apertures formed in the motor casing portion 20 and through which a primary air flow is drawn into the base 16 from the external environment. In this embodiment the base 16 of the pedestal 12 has a height in the range from 200 to 300 mm, and the motor casing portion 20 has a diameter in the range from 100 to 200 mm. The base plate 24 preferably has a diameter in the range from 200 to 300 mm.

The telescopic duct 18 of the pedestal 12 is moveable between a fully extended configuration, as illustrated in Figure 1, and a retracted configuration, as illustrated in Figure 2. The duct 18 comprises a substantially cylindrical base 32 mounted on the base 12 of the fan assembly 10, an outer tubular member 34 which is connected to, and extends upwardly from, the base 32, and an inner tubular member 36 which is located partially within the outer tubular member 34. A connector 37 connects the nozzle 14 to the open upper end of the inner tubular member 36 of the duct 18. The inner tubular member 36 is slidable relative to, and within, the outer tubular member 34 between a fully extended position, as illustrated in Figure 1, and a retracted position, as illustrated in Figure 2. When the inner tubular member 36 is in the fully extended position, the fan assembly 10 preferably has a height in the range from 1200 to 1600 mm, whereas when the inner tubular member 36 is in the retracted position, the fan assembly 10 preferably has a height in the range from 900 to 1300 mm. To adjust the height of the fan assembly 10, the user may grasp an exposed portion of the inner tubular member 36 and slide the inner tubular member 36 in either an upward or a downward direction as desired so that nozzle 14 is at the desired vertical position. When the inner tubular member 36 is in its retracted position, the user may grasp the connector 37 to pull the inner tubular member 36 upwards.

The nozzle 14 has an annular shape, extending about a central axis X to define an opening 38. The nozzle 14 comprises a mouth 40 located towards the rear of the nozzle 14 for emitting the primary air flow from the fan assembly 10 and through the opening 38. The mouth 40 extends about the opening 38, and is preferably also annular. The inner periphery of the nozzle 14 comprises a Coanda surface 42 located adjacent the

mouth 40 and over which the mouth 40 directs the air emitted from the fan assembly 10, a diffuser surface 44 located downstream of the Coanda surface 42 and a guide surface 46 located downstream of the diffuser surface 44. The diffuser surface 44 is arranged to taper away from the central axis X of the opening 38 in such a way so as to assist the flow of air emitted from the fan assembly 10. The angle subtended between the diffuser surface 44 and the central axis X of the opening 38 is in the range from 5 to 25°, and in this example is around 7°. The guide surface 46 is arranged at an angle to the diffuser surface 44 to further assist the efficient delivery of a cooling air flow from the fan assembly 10. The guide surface 46 is preferably arranged substantially parallel to the central axis X of the opening 38 to present a substantially flat and substantially smooth face to the air flow emitted from the mouth 40. A visually appealing tapered surface 48 is located downstream from the guide surface 46, terminating at a tip surface 50 lying substantially perpendicular to the central axis X of the opening 38. The angle subtended between the tapered surface 48 and the central axis X of the opening 38 is preferably around 45°. In this embodiment, the nozzle 14 has a height in the range from 400 to 600 mm.

Figure 3 illustrates a sectional view through the base 16 of the pedestal 12. The lower casing portion 22 of the base 16 houses a controller, indicated generally at 52, for controlling the operation of the fan assembly 10 in response to depression of the user operable buttons 26 shown in Figures 1 and 2, and/or manipulation of the user operable dial 28. The lower casing portion 22 may optionally comprise a sensor 54 for receiving control signals from a remote control (not shown), and for conveying these control signals to the controller 52. These control signals are preferably infrared signals. The sensor 54 is located behind a window 55 through which the control signals enter the lower casing portion 22 of the base 16. A light emitting diode (not shown) may be provided for indicating whether the fan assembly 10 is in a stand-by mode. The lower casing portion 22 also houses a mechanism, indicated generally at 56, for oscillating the motor casing portion 20 of the base 16 relative to the lower casing portion 22 of the base 16. The oscillating mechanism 56 comprises a rotatable shaft 56a which extends from the lower casing portion 22 into the motor casing portion 20. The shaft 56a is

supported within a sleeve 56b connected to the lower casing portion 22 by bearings to allow the shaft 56a to rotate relative to the sleeve 56b. One end of the shaft 56a is connected to the central portion of an annular connecting plate 56c, whereas the outer portion of the connecting plate 56c is connected to the base of the motor casing portion 20. This allows the motor casing portion 20 to be rotated relative to the lower casing portion 22. The oscillating mechanism 56 also comprises a motor (not shown) located within the lower casing portion 22 which operates a crank arm mechanism, indicated generally at 56d, which oscillates the base of the motor casing portion 20 relative to an upper portion of the lower casing portion 22. Crank arm mechanisms for oscillating one part relative to another are generally well known, and so will not be described here. The range of each oscillation cycle of the motor casing portion 20 relative to the lower casing portion 22 is preferably between 60° and 120°, and in this embodiment is around 90°. In this embodiment, the oscillating mechanism 56 is arranged to perform around 3 to 5 oscillation cycles per minute. A mains power cable 58 extends through an aperture formed in the lower casing portion 22 for supplying electrical power to the fan assembly 10.

The motor casing portion 20 comprises a cylindrical grille 60 in which an array of apertures 62 is formed to provide the air inlets 30 of the base 16 of the pedestal 12. The motor casing portion 20 houses an impeller 64 for drawing the primary air flow through the apertures 62 and into the base 16. Preferably, the impeller 64 is in the form of a mixed flow impeller. The impeller 64 is connected to a rotary shaft 66 extending outwardly from a motor 68. In this embodiment, the motor 68 is a DC brushless motor having a speed which is variable by the controller 52 in response to user manipulation of the dial 28 and/or a signal received from the remote control. The maximum speed of the motor 68 is preferably in the range from 5,000 to 10,000 rpm. The motor 68 is housed within a motor bucket comprising an upper portion 70 connected to a lower portion 72. The upper portion 70 of the motor bucket comprises a diffuser 74 in the form of a stationary disc having spiral blades. The motor bucket is located within, and mounted on, a generally frusto-conical impeller housing 76 connected to the motor casing portion 20. The impeller 64 and the impeller housing 76 are shaped so that the

impeller 64 is in close proximity to, but does not contact, the inner surface of the impeller housing 76. A substantially annular inlet member 78 is connected to the bottom of the impeller housing 76 for guiding the primary air flow into the impeller housing 76.

5

Preferably, the base 16 of the pedestal 12 further comprises silencing foam for reducing noise emissions from the base 16. In this embodiment, the motor casing portion 20 of the base 16 comprises a first annular foam member 80 located beneath the grille 60, and a second annular foam member 82 located between the impeller housing 76 and the inlet member 78.

10

The telescopic duct 18 of the pedestal 12 will now be described in more detail with reference to Figures 4 to 11. The base 32 of the duct 18 comprises a substantially cylindrical side wall 102 and an annular upper surface 104 which is substantially orthogonal to, and preferably integral with, the side wall 102. The side wall 102 preferably has substantially the same external diameter as the motor casing portion 20 of the base 16, and is shaped so that the external surface of the side wall 102 is substantially flush with the external surface of the motor casing portion 20 of the base 16 when the duct 18 is connected to the base 16. The base 32 further comprises a relatively short air pipe 106 extending upwardly from the upper surface 104 for conveying the primary air flow into the outer tubular member 34 of the duct 18. The air pipe 106 is preferably substantially co-axial with the side wall 102, and has an external diameter which is slightly smaller than the internal diameter of the outer tubular member 34 of the duct 18 to enable the air pipe 106 to be fully inserted into the outer tubular member 34 of the duct 18. A plurality of axially-extending ribs 108 may be located on the outer surface of the air pipe 106 for forming an interference fit with the outer tubular member 34 of the duct 18 and thereby secure the outer tubular member 34 to the base 32. An annular sealing member 110 is located over the upper end of the air pipe 106 to form an air-tight seal between the outer tubular member 34 and the air pipe 106.

15

20

25

30

The duct 18 comprises a domed air guiding member 114 for guiding the primary air flow emitted from the diffuser 74 into the air pipe 106. The air guiding member 114 has an open lower end 116 for receiving the primary air flow from the base 16, and an open upper end 118 for conveying the primary air flow into the air pipe 106. The air guiding member 114 is housed within the base 32 of the duct 18. The air guiding member 114 is connected to the base 32 by means of co-operating snap-fit connectors 120 located on the base 32 and the air guiding member 114. A second annular sealing member 121 is located about the open upper end 118 for forming an air-tight sealing between the base 32 and the air guiding member 114. As illustrated in Figure 3, the air guiding member 114 is connected to the open upper end of the motor casing portion 20 of the base 16, for example by means of co-operating snap-fit connectors 123 or screw-threaded connectors located on the air guiding member 114 and the motor casing portion 20 of the base 16. Thus, the air guiding member 114 serves to connect the duct 18 to the base 16 of the pedestal 12.

A plurality of air guiding vanes 122 are located on the inner surface of the air guiding member 114 for guiding the spiraling air flow emitted from the diffuser 74 into the air pipe 106. In this example, the air guiding member 114 comprises seven air guiding vanes 122 which are evenly spaced about the inner surface of the air guiding member 114. The air guiding vanes 122 meet at the centre of the open upper end 118 of the air guiding member 114, and thus define a plurality of air channels 124 within the air guiding member 114 each for guiding a respective portion of the primary air flow into the air pipe 106. With particular reference to Figure 4, seven radial air guiding vanes 126 are located within the air pipe 106. Each of these radial air guiding vanes 126 extends along substantially the entire length of the air pipe 106, and adjoins a respective one of the air guiding vanes 122 when the air guiding member 114 is connected to the base 32. The radial air guiding vanes 126 thus define a plurality of axially-extending air channels 128 within the air pipe 106 which each receive a respective portion of the primary air flow from a respective one of the air channels 124 within the air guiding member 114, and which convey that portion of the primary flow axially through the air pipe 106 and into the outer tubular member 34 of the duct 18. Thus, the base 32 and the

air guiding member 114 of the duct 18 serve to convert the spiraling air flow emitted from the diffuser 74 into an axial air flow which passes through the outer tubular member 34 and the inner tubular member 36 to the nozzle 14. A third annular sealing member 129 may be provided for forming an air-tight seal between the air guiding member 114 and the base 32 of the duct 18.

A cylindrical upper sleeve 130 is connected, for example using an adhesive or through an interference fit, to the inner surface of the upper portion of the outer tubular member 34 so that the upper end 132 of the upper sleeve 130 is level with the upper end 134 of the outer tubular member 34. The upper sleeve 130 has an internal diameter which is slightly greater than the external diameter of the inner tubular member 36 to allow the inner tubular member 36 to pass through the upper sleeve 130. A third annular sealing member 136 is located on the upper sleeve 130 for forming an air-tight seal with the inner tubular member 36. The third annular sealing member 136 comprises an annular lip 138 which engages the upper end 132 of the outer tubular member 34 to form an air-tight seal between the upper sleeve 130 and the outer tubular member 34.

A cylindrical lower sleeve 140 is connected, for example using an adhesive or through an interference fit, to the outer surface of the lower portion of the inner tubular member 36 so that the lower end 142 of the inner tubular member 36 is located between the upper end 144 and the lower end 146 of the lower sleeve 140. The upper end 144 of the lower sleeve 140 has substantially the same external diameter as the lower end 148 of the upper sleeve 130. Thus, in the fully extended position of the inner tubular member 36 the upper end 144 of the lower sleeve 140 abuts the lower end 148 of the upper sleeve 130, thereby preventing the inner tubular member 36 from being withdrawn fully from the outer tubular member 34. In the retracted position of the inner tubular member 36, the lower end 146 of the lower sleeve 140 abuts the upper end of the air pipe 106.

A mainspring 150 is coiled around an axle 152 which is rotatably supported between inwardly extending arms 154 of the lower sleeve 140 of the duct 18, as illustrated in Figure 7. With reference to Figure 8, the mainspring 150 comprises a steel strip which

has a free end 156 fixedly located between the external surface of the upper sleeve 130 and the internal surface of the outer tubular member 34. Consequently, the mainspring 150 is unwound from the axle 152 as the inner tubular member 36 is lowered from the fully extended position, as illustrated in Figures 5 and 6, to the retracted position, as illustrated in Figures 10 and 11. The elastic energy stored within the mainspring 150 acts as a counter-weight for maintaining a user-selected position of the inner tubular member 36 relative to the outer tubular member 34.

Additional resistance to the movement of the inner tubular member 36 relative to the outer tubular member 34 is provided by a spring-loaded, arcuate band 158, preferably formed from plastics material, located within an annular groove 160 extending circumferentially about the lower sleeve 140. With reference to Figures 7 and 9, the band 158 does not extend fully about the lower sleeve 140, and so comprises two opposing ends 161. Each end 161 of the band 158 comprises a radially inner portion 161a which is received within an aperture 162 formed in the lower sleeve 140. A compression spring 164 is located between the radially inner portions 161a of the ends 161 of the band 158 to urge the external surface of the band 158 against the internal surface of the outer tubular member 34, thereby increasing the frictional forces which resist movement of the inner tubular member 36 relative to the outer tubular member 34.

The band 158 further comprises a grooved portion 166, which in this embodiment is located opposite to the compression spring 164, which defines an axially extending groove 167 on the external surface of the band 158. The groove 167 of the band 158 is located over a raised rib 168 which extends axially along the length of its internal surface of the outer tubular member 34. The groove 167 has substantially the same angular width and radial depth as the raised rib 168 to inhibit relative rotation between the inner tubular member 36 and the outer tubular member 34.

The nozzle 14 of the fan assembly 10 will now be described with reference to Figures 12 to 15. The nozzle 14 comprises an annular outer casing section 200 connected to and

extending about an annular inner casing section 202. Each of these sections may be formed from a plurality of connected parts, but in this embodiment each of the outer casing section 200 and the inner casing section 202 is formed from a respective, single moulded part. The inner casing section 202 defines the central opening 38 of the nozzle 14, and has an external peripheral surface 203 which is shaped to define the Coanda surface 42, diffuser surface 44, guide surface 46 and tapered surface 48.

The outer casing section 200 and the inner casing section 202 together define an annular interior passage 204 of the nozzle 14. Thus, the interior passage 204 extends about the opening 38. The interior passage 204 is bounded by the internal peripheral surface 206 of the outer casing section 200 and the internal peripheral surface 208 of the inner casing section 202. The base of the outer casing section 200 comprises an aperture 210.

The connector 37 which connects the nozzle 14 to the open upper end 170 of the inner tubular member 36 of the duct 18 comprises a tilting mechanism for tilting the nozzle 12 relative to the pedestal 14. The tilting mechanism comprises an upper member which is in the form of a plate 300 which is fixedly located within the aperture 210. Optionally, the plate 300 may be integral with the outer casing section 200. The plate 300 comprises a circular aperture 302 through which the primary air flow enters the interior passage 204 from the telescopic duct 18. The connector 37 further comprises a lower member in the form of an air pipe 304 which is at least partially inserted through the open upper end 170 of the inner tubular member 36. This air pipe 304 has substantially the same internal diameter as the circular aperture 302 formed in the upper plate 300 of the connector 37. If required, an annular sealing member may be provided for forming an air-tight seal between the inner surface of the inner tubular member 36 and the outer surface of the air pipe 304, and inhibits the withdrawal of the air pipe 304 from the inner tubular member 36. The plate 300 is pivotably connected to the air pipe 304 using a series of connectors indicated generally at 306 in Figure 12 and which are covered by end caps 308. A flexible hose 310 extends between the air pipe 304 and the plate 300 for conveying air therebetween. The flexible hose 310 may be in the form of an annular bellows sealing element. A first annular sealing member 312 forms an air-

tight seal between the hose 310 and the air pipe 304, and a second annular sealing member 314 forms an air-tight seal between the hose 310 and the plate 300. To tilt the nozzle 12 relative to the pedestal 14, the user simply pulls or pushes the nozzle 12 to cause the hose 310 to bend to allow the plate 300 to move relative to the air pipe 304.

5 The force required to move the nozzle 12 depends on the tightness of the connection between the plate 300 and the air pipe 304, and is preferably in the range from 2 to 4 N. The nozzle 12 is preferably moveable within a range of $\pm 10^\circ$ from an untilted position, in which the axis X is substantially horizontal, to a fully tilted position. As the nozzle 12 is tilted relative to the pedestal 14, the axis X is swept along a substantially vertical
10 plane.

The mouth 40 of the nozzle 14 is located towards the rear of the nozzle 10. The mouth 40 is defined by overlapping, or facing, portions 212, 214 of the internal peripheral surface 206 of the outer casing section 200 and the external peripheral surface 203 of
15 the inner casing section 202, respectively. In this example, the mouth 40 is substantially annular and, as illustrated in Figure 15, has a substantially U-shaped cross-section when sectioned along a line passing diametrically through the nozzle 14. In this example, the overlapping portions 212, 214 of the internal peripheral surface 206 of the outer casing section 200 and the external peripheral surface 203 of the inner casing section 202 are
20 shaped so that the mouth 40 tapers towards an outlet 216 arranged to direct the primary flow over the Coanda surface 42. The outlet 216 is in the form of an annular slot, preferably having a relatively constant width in the range from 0.5 to 5 mm. In this example the outlet 216 has a width in the range from 0.5 to 1.5 mm. Spacers may be spaced about the mouth 40 for urging apart the overlapping portions 212, 214 of the
25 internal peripheral surface 206 of the outer casing section 200 and the external peripheral surface 203 of the inner casing section 202 to maintain the width of the outlet 216 at the desired level. These spacers may be integral with either the internal peripheral surface 206 of the outer casing section 200 or the external peripheral surface 203 of the inner casing section 202.

30

To operate the fan assembly 10, the user depresses an appropriate one of the buttons 26 on the base 16 of the pedestal 12, in response to which the controller 52 activates the motor 68 to rotate the impeller 64. The rotation of the impeller 64 causes a primary air flow to be drawn into the base 16 of the pedestal 12 through the apertures 62 of the grille 60. Depending on the speed of the motor 68, the primary air flow may be between 20 and 40 litres per second. The primary air flow passes sequentially through the impeller housing 76 and the diffuser 74. The spiral form of the blades of the diffuser 74 causes the primary air flow to be exhausted from the diffuser 74 in the form of spiraling air flow. The primary air flow enters the air guiding member 114, wherein the curved air guiding vanes 122 divide the primary air flow into a plurality of portions, and guide each portion of the primary air flow into a respective one of the axially-extending air channels 128 within the air pipe 106 of the base 32 of the telescopic duct 18. The portions of the primary air flow merge into an axial air flow as they are emitted from the air pipe 106. The primary air flow passes upwards through the outer tubular member 34 and the inner tubular member 36 of the duct 18, and through the connector 37 to enter the interior passage 86 of the nozzle 14.

Within the nozzle 14, the primary air flow is divided into two air streams which pass in opposite directions around the central opening 38 of the nozzle 14. As the air streams pass through the interior passage 204, air enters the mouth 40 of the nozzle 14. The air flow into the mouth 40 is preferably substantially even about the opening 38 of the nozzle 14. Within the mouth 40, the flow direction of the air stream is substantially reversed. The air stream is constricted by the tapering section of the mouth 40 and emitted through the outlet 216.

The primary air flow emitted from the mouth 40 is directed over the Coanda surface 42 of the nozzle 14, causing a secondary air flow to be generated by the entrainment of air from the external environment, specifically from the region around the outlet 216 of the mouth 40 and from around the rear of the nozzle 14. This secondary air flow passes through the central opening 38 of the nozzle 14, where it combines with the primary air flow to produce a total air flow, or air current, projected forward from the nozzle 14.

Depending on the speed of the motor 68, the mass flow rate of the air current projected forward from the fan assembly 10 may be up to 400 litres per second, preferably up to 600 litres per second, and more preferably up to 800 litres per second, and the maximum speed of the air current may be in the range from 2.5 to 4.5 m/s.

5

The even distribution of the primary air flow along the mouth 40 of the nozzle 14 ensures that the air flow passes evenly over the diffuser surface 44. The diffuser surface 44 causes the mean speed of the air flow to be reduced by moving the air flow through a region of controlled expansion. The relatively shallow angle of the diffuser surface 44 to the central axis X of the opening 38 allows the expansion of the air flow to occur gradually. A harsh or rapid divergence would otherwise cause the air flow to become disrupted, generating vortices in the expansion region. Such vortices can lead to an increase in turbulence and associated noise in the air flow which can be undesirable, particularly in a domestic product such as a fan. The air flow projected forwards beyond the diffuser surface 44 can tend to continue to diverge. The presence of the guide surface 46 extending substantially parallel to the central axis X of the opening 38 further converges the air flow. As a result, the air flow can travel efficiently out from the nozzle 14, enabling the air flow can be experienced rapidly at a distance of several metres from the fan assembly 10.

10
15
20

CLAIMS

1. A fan assembly comprising means for creating an air flow and an air outlet for
5 emitting the air flow, the air outlet being mounted on a pedestal housing said means for
creating an air flow, the pedestal comprising a base and a height adjustable stand, the
base comprising means for oscillating the stand, the air outlet and said means for
creating an air flow.
- 10 2. A fan assembly as claimed in claim 1, wherein the oscillating means is arranged
to oscillate an upper portion of the base relative to a lower portion of the base.
3. A fan assembly as claimed in claim 2, wherein the upper portion of the base
15 comprises a shaft extending into the lower portion of the base, the lower portion of the
base comprising a sleeve for receiving the shaft.
4. A fan assembly as claimed in claim 3, wherein the shaft is rotatably supported
with the sleeve by at least one bearing.
- 20 5. A fan assembly as claimed in any of claims 2 to 4, wherein the oscillating means
comprises a crank mechanism for oscillating the upper portion of the base relative to the
lower portion of the base.
6. A fan assembly as claimed in any of claims 2 to 5, wherein the upper portion of
25 the base houses said means for creating an air flow.
7. A fan assembly as claimed in any of the preceding claims, wherein the stand
comprises a duct for conveying the air flow to the air outlet.

8. A fan assembly as claimed in claim 7, wherein the means for creating an air flow comprises an impeller, a motor for rotating the impeller, and a diffuser located downstream from the impeller.

5 9. A fan assembly as claimed in claim 8, comprising means for guiding the air flow emitted from the diffuser into the duct.

10. A fan assembly as claimed in claim 9, wherein the air flow guiding means comprises a plurality of vanes each for guiding a respective portion of the air flow
10 emitted from the diffuser towards the duct.

11. A fan assembly as claimed in claim 10, wherein the air flow guiding means comprises a plurality of radial vanes located at least partially within the duct, each of the radial vanes adjoining a respective one of the plurality of vanes.

15

12. A fan assembly as claimed in any of the preceding claims, wherein the air outlet extends about an opening through which air from outside the fan assembly is drawn by the air flow emitted from the air outlet.

20 13. A fan assembly as claimed in claim 12, wherein the air outlet comprises a nozzle comprising an interior passage for receiving the air flow and a mouth for emitting the air flow.

14. A fan assembly as claimed in claim 13, wherein the interior passage is shaped to
25 divide the received air flow into two air streams each flowing along a respective side of the opening.

15. A fan assembly as claimed in claim 13 or claim 14, wherein the interior passage is substantially annular.

30

16. A fan assembly as claimed in any of claims 13 to 15, wherein the mouth extends about the opening.

17. A fan assembly as claimed in any of claims 13 to 16, wherein the nozzle
5 comprises an inner casing section and an outer casing section which together define the mouth.

18. A fan assembly as claimed in claim 17, wherein the mouth comprises an outlet
10 located between an external surface of the inner casing section of the nozzle and an internal surface of the outer casing section of the nozzle.

19. A fan assembly as claimed in claim 18, wherein the outlet is in the form of a slot extending at least partially about the opening.

15 20. A fan assembly as claimed in claim 18 or claim 19, wherein the outlet has a width in the range from 0.5 to 5 mm.

21. A fan assembly as claimed in any of the preceding claims, wherein the fan
assembly is a bladeless fan assembly.

20

22. A fan assembly substantially as hereinbefore described with reference to the accompanying drawings.

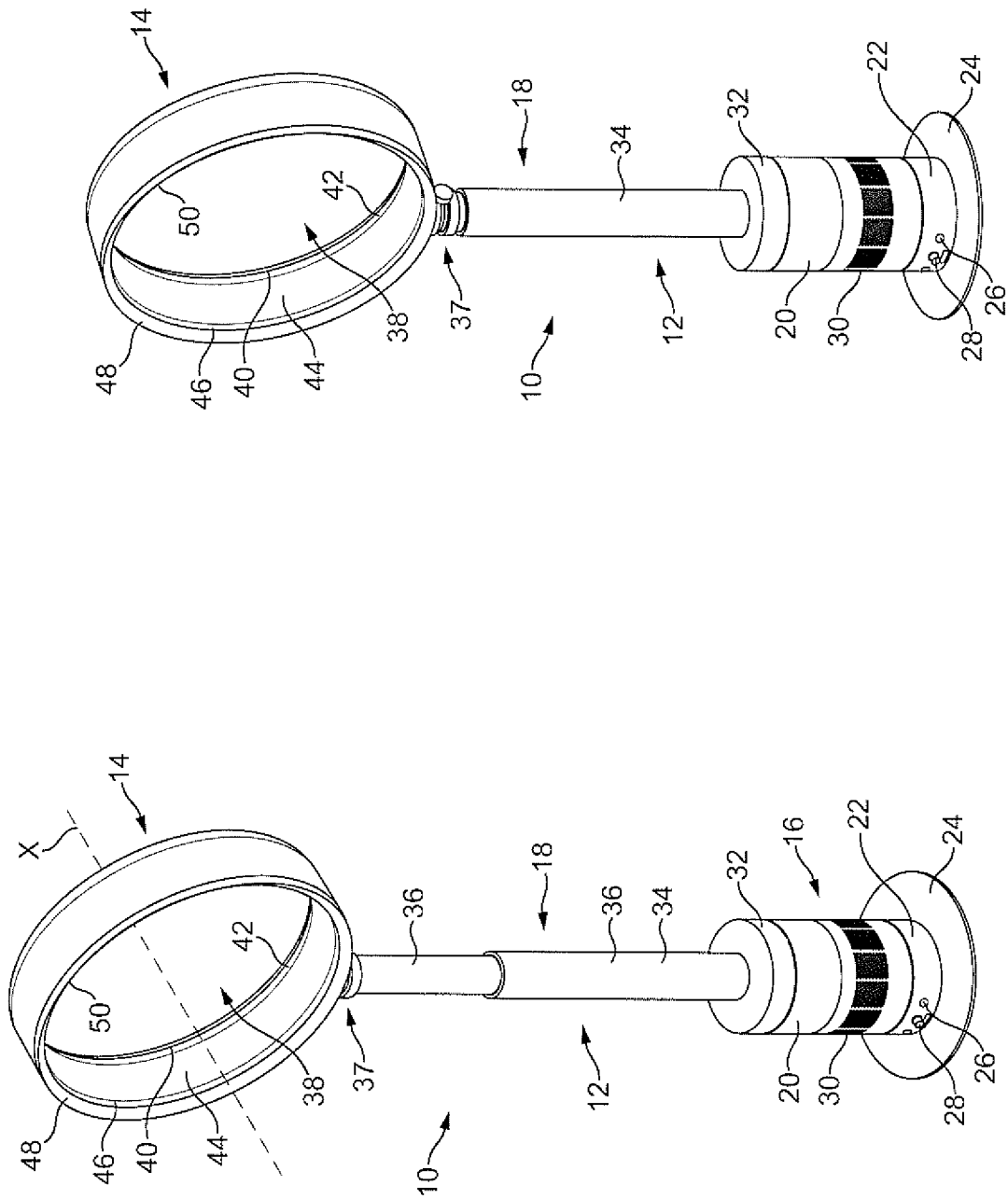

FIG. 2

FIG. 1

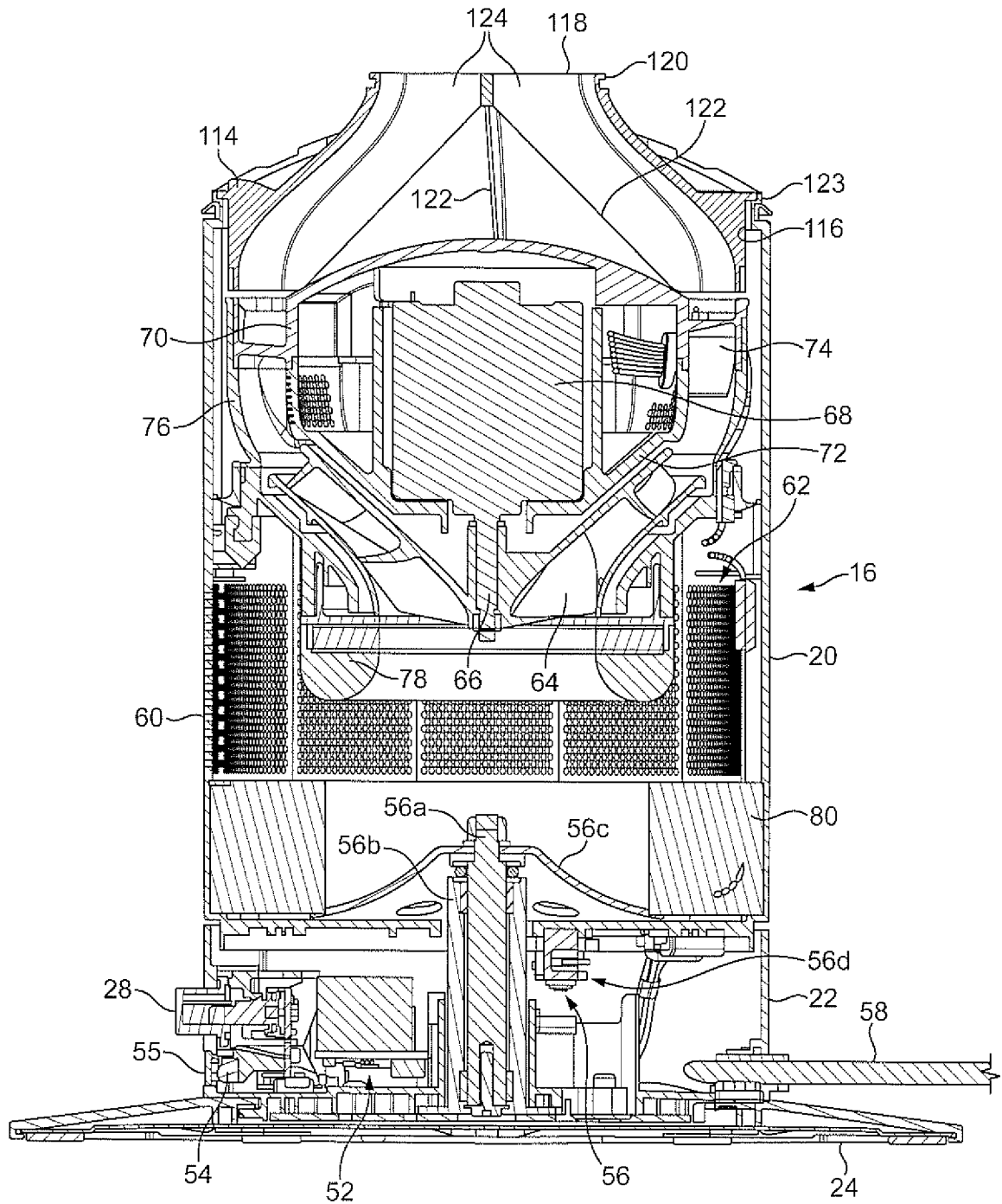

FIG. 3

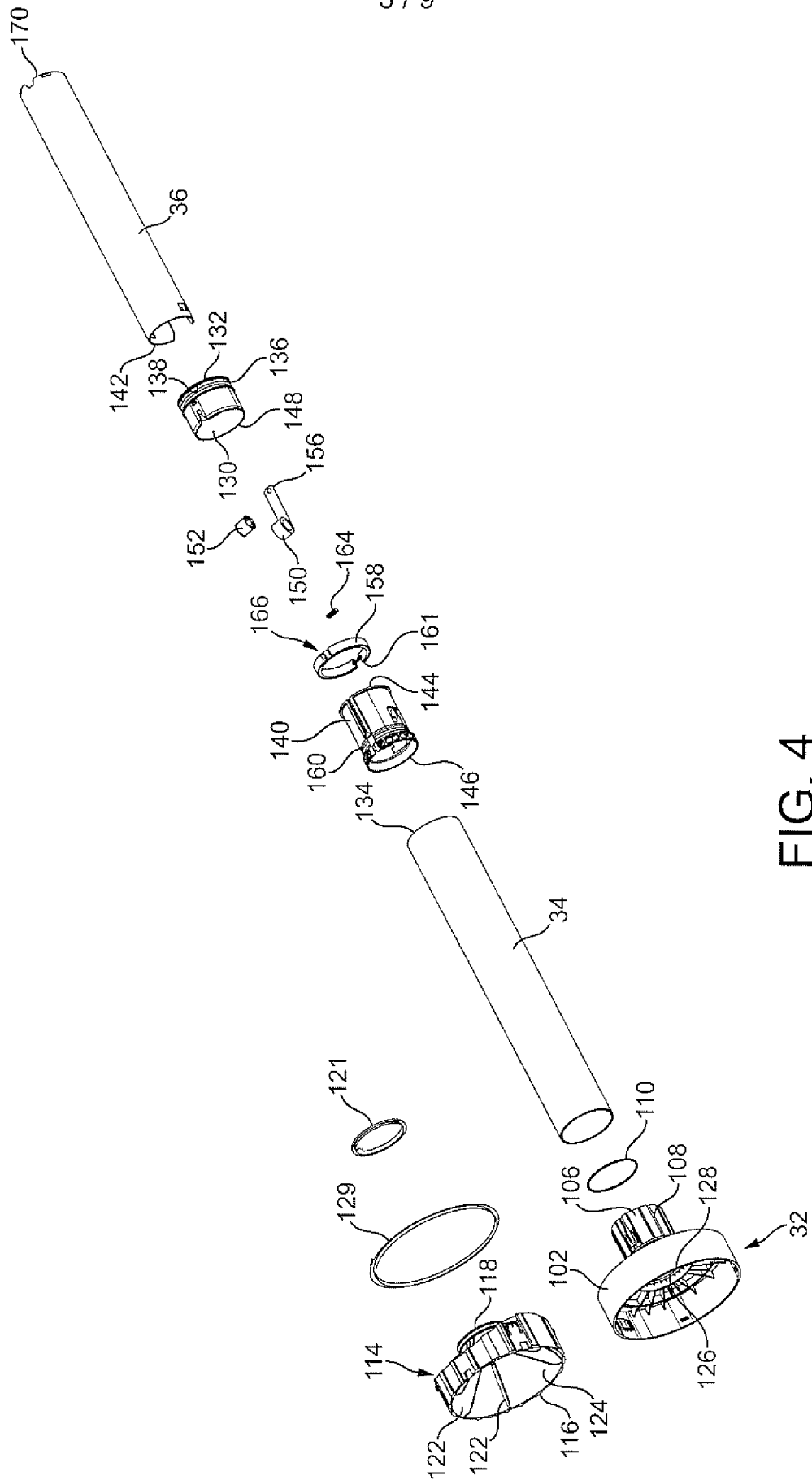

FIG. 4

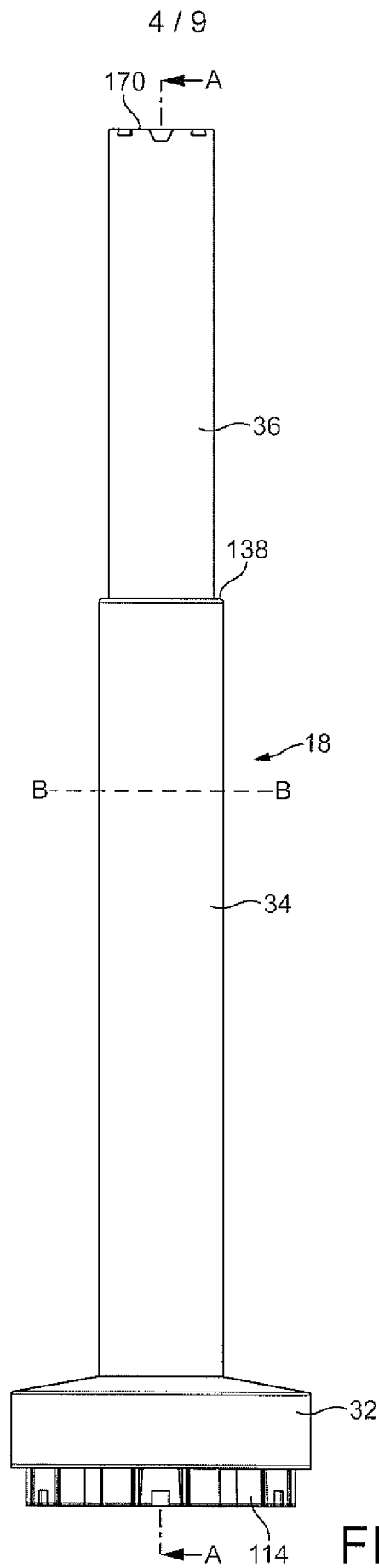

FIG. 5

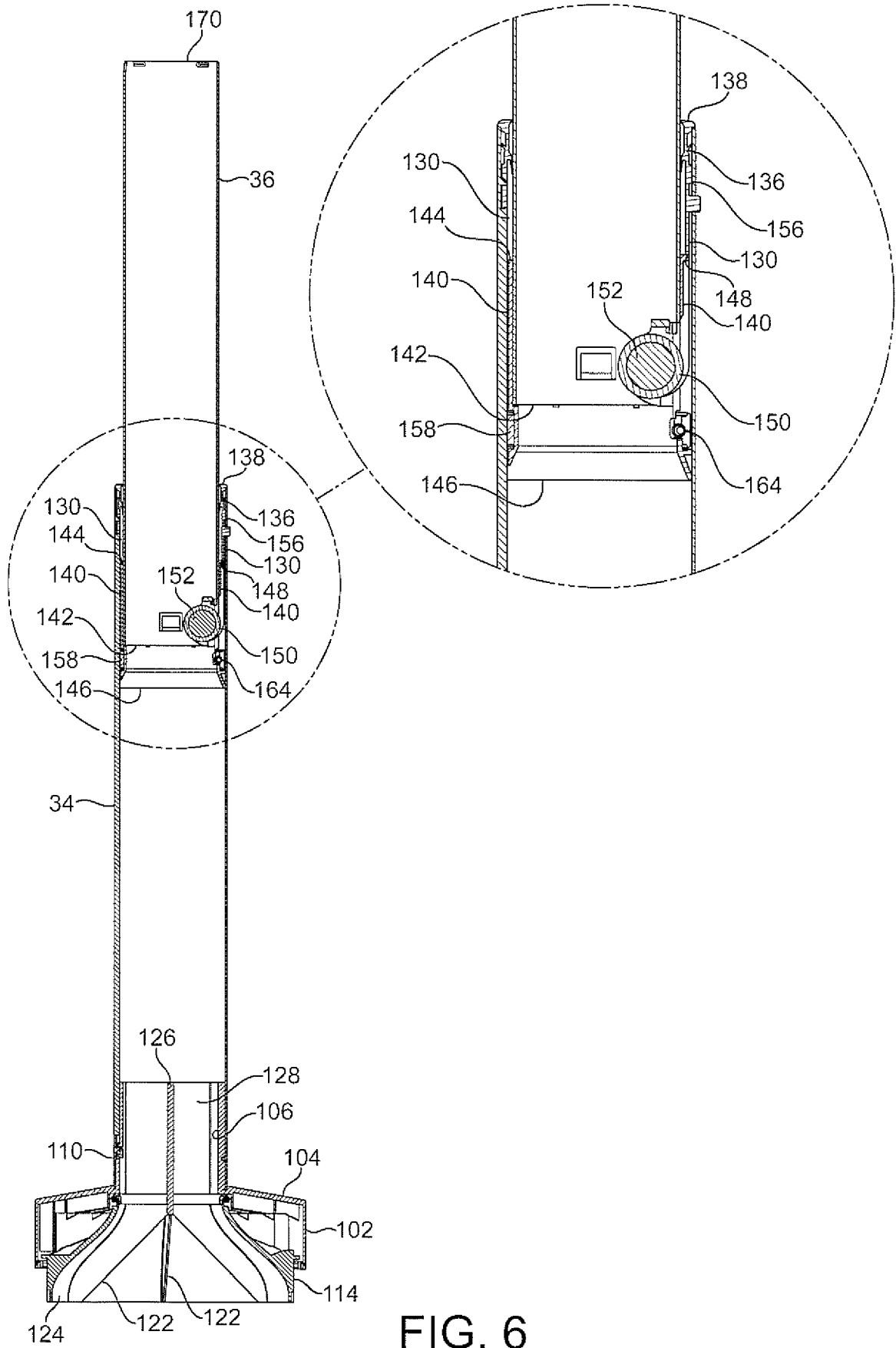

FIG. 6

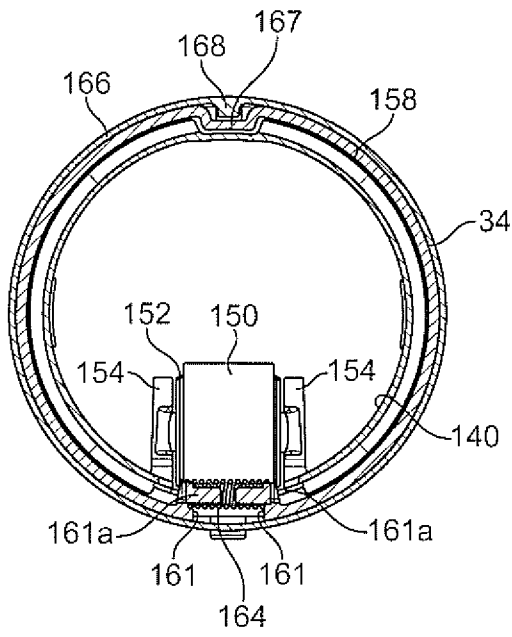

FIG. 7

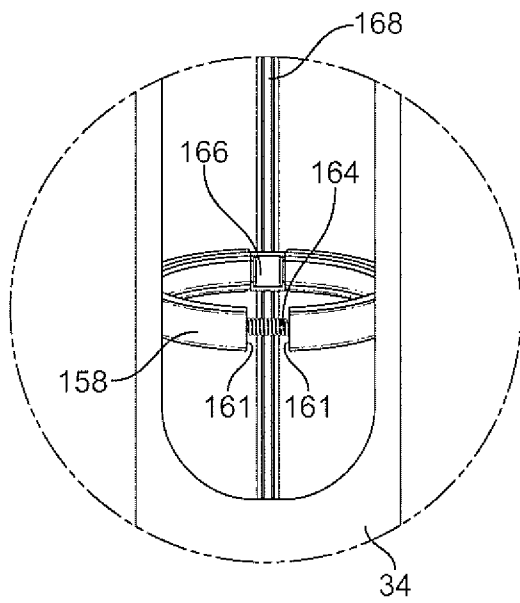

FIG. 9

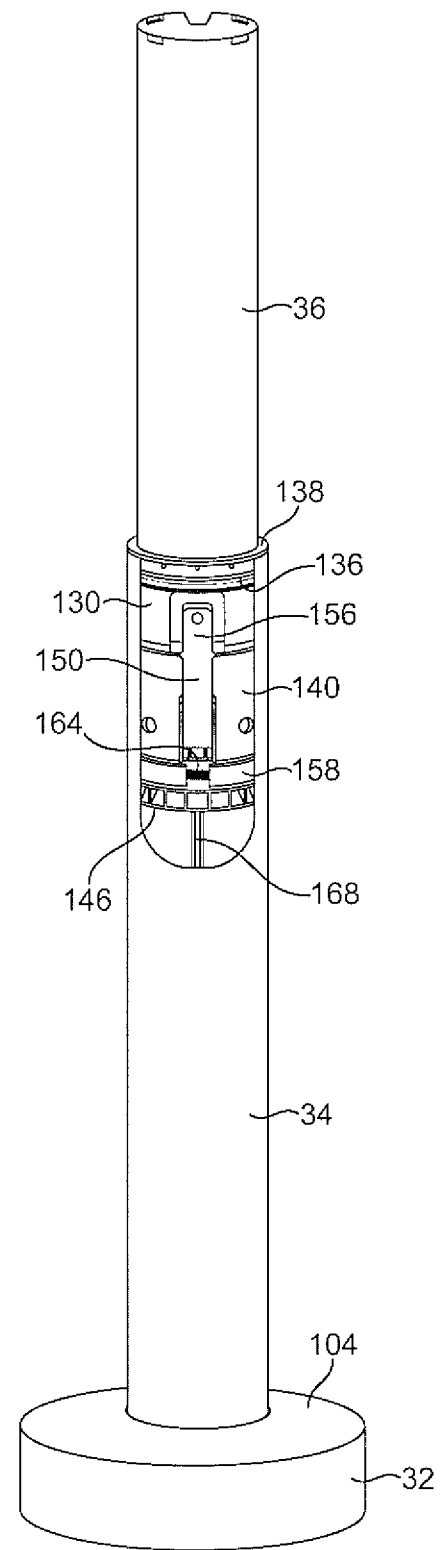

FIG. 8

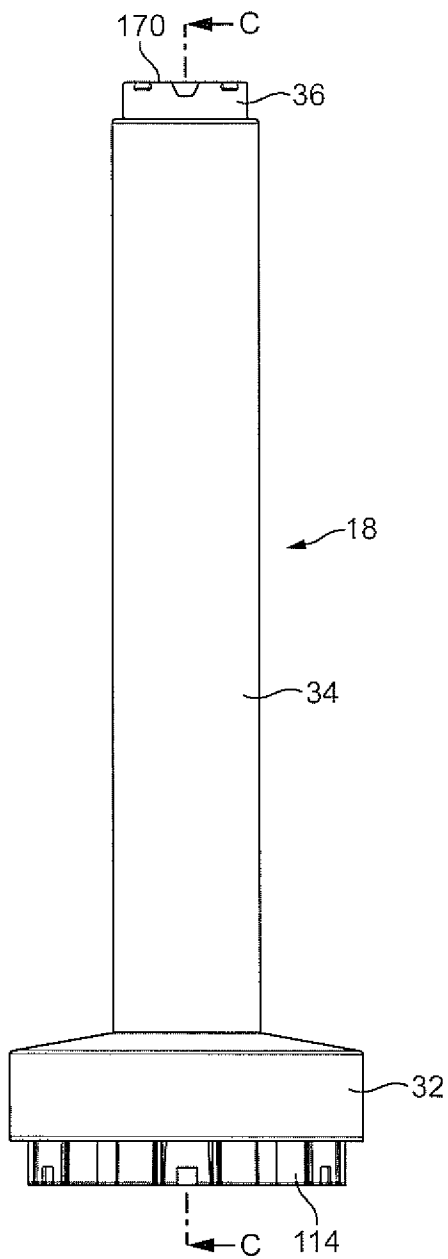

FIG. 10

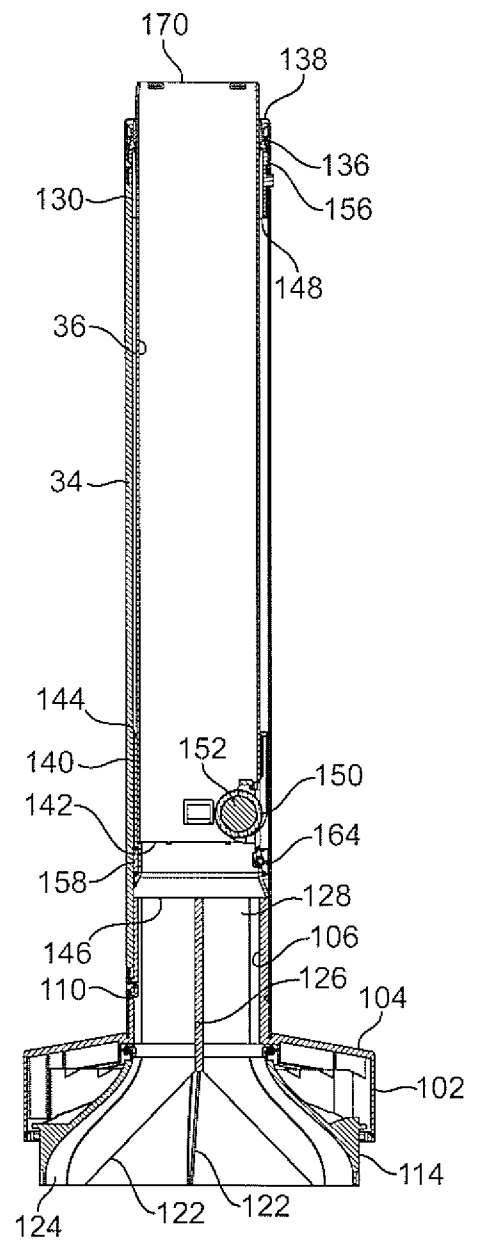

FIG. 11

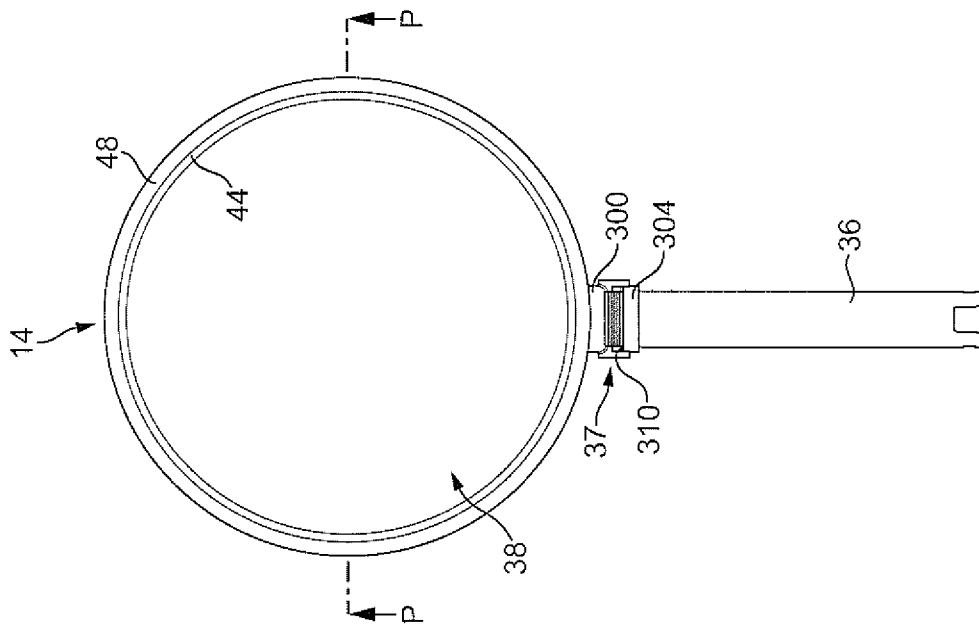

FIG. 13

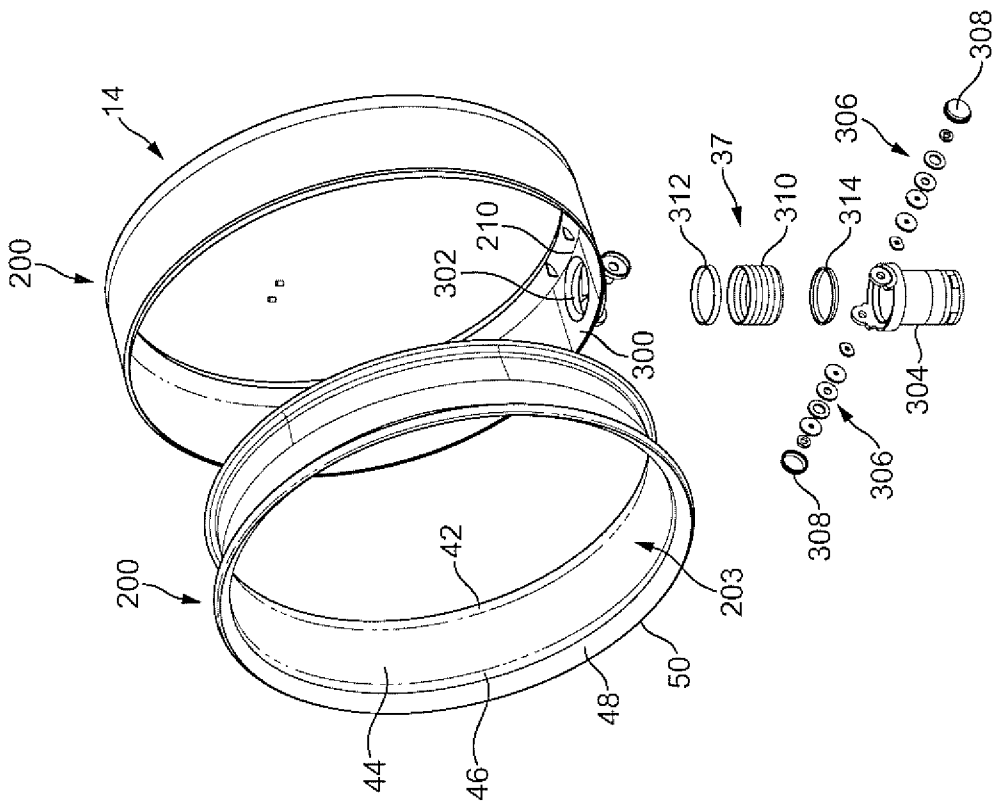

FIG. 12

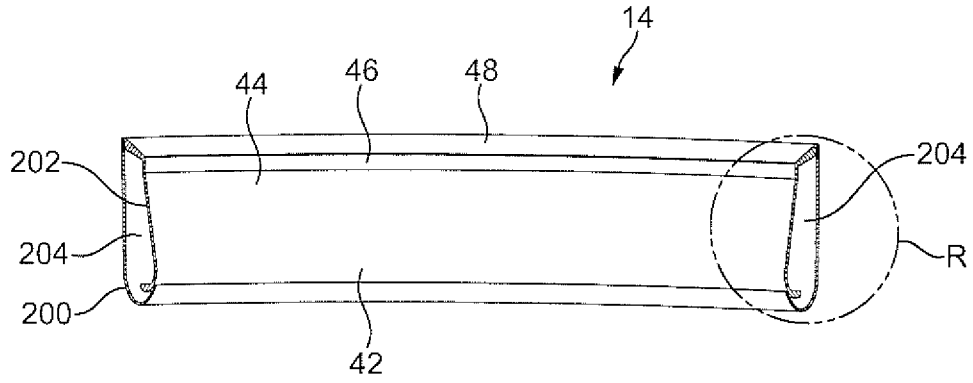

FIG. 14

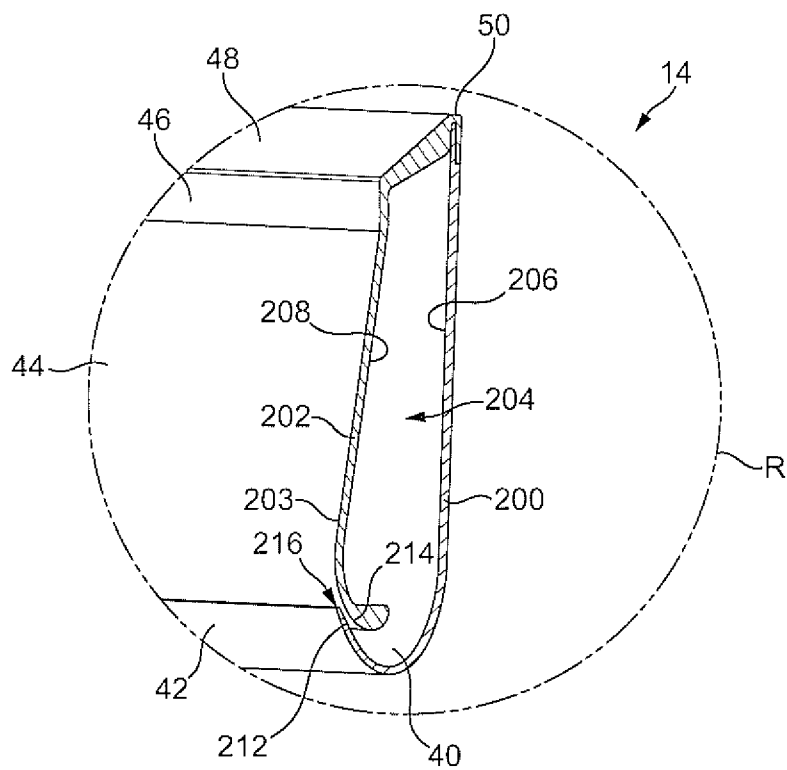

FIG. 15

INTERNATIONAL SEARCH REPORT

International application No
PCT/GB2010/050282

A. CLASSIFICATION OF SUBJECT MATTER
 INV. F24F13/32 F04D25/10
 ADD.
 According to International Patent Classification (IPC) or to both national classification and IPC

B. FIELDS SEARCHED
 Minimum documentation searched (classification system followed by classification symbols)
 F24F F04D

Documentation searched other than minimum documentation to the extent that such documents are included in the fields searched

Electronic data base consulted during the international search (name of data base and, where practical, search terms used)
 EPO-Internal

C. DOCUMENTS CONSIDERED TO BE RELEVANT

Category*	Citation of document, with indication, where appropriate, of the relevant passages	Relevant to claim No.
X	US 2005/053465 A1 (ROACH KENNETH [US] ET AL) 10 March 2005 (2005-03-10) * abstract paragraph [0020] - paragraph [0021]; figures 1,2	1-8
X	US 2009/026850 A1 (FU CHIAO [TW]) 29 January 2009 (2009-01-29) paragraph [0013]	1-8
X	WO 2008/014641 A1 (WANG PAO-CHU [CN]; WANG LIN LI-YEN [CN]) 7 February 2008 (2008-02-07) * abstract	1-8
A	US 2 808 198 A (HACKLEY MORRISON) 1 October 1957 (1957-10-01) the whole document	1-22

Further documents are listed in the continuation of Box C. See patent family annex.

* Special categories of cited documents :

A document defining the general state of the art which is not considered to be of particular relevance	*T* later document published after the international filing date or priority date and not in conflict with the application but cited to understand the principle or theory underlying the invention
E earlier document but published on or after the international filing date	*X* document of particular relevance; the claimed invention cannot be considered novel or cannot be considered to involve an inventive step when the document is taken alone
L document which may throw doubts on priority claim(s) or which is cited to establish the publication date of another citation or other special reason (as specified)	*Y* document of particular relevance; the claimed invention cannot be considered to involve an inventive step when the document is combined with one or more other such documents, such combination being obvious to a person skilled in the art.
O document referring to an oral disclosure, use, exhibition or other means	*&* document member of the same patent family
P document published prior to the international filing date but later than the priority date claimed	

Date of the actual completion of the international search 8 July 2010	Date of mailing of the international search report 27/07/2010
--	--

Name and mailing address of the ISA/ European Patent Office, P.B. 5818 Patentlaan 2 NL - 2280 HV Rijswijk Tel. (+31-70) 340-2040, Fax: (+31-70) 340-3016	Authorized officer Vuc, Arianda
--	--

INTERNATIONAL SEARCH REPORT

International application No
PCT/GB2010/050282

C(Continuation). DOCUMENTS CONSIDERED TO BE RELEVANT		
Category*	Citation of document, with indication, where appropriate, of the relevant passages	Relevant to claim No.
A	US 2004/149881 A1 (ALLEN DAVID S [US]) 5 August 2004 (2004-08-05) * abstract; figure 1 -----	1-22
A	US 2 336 295 A (CARYL REIMULLER) 7 December 1943 (1943-12-07) the whole document -----	1-22

INTERNATIONAL SEARCH REPORT

Information on patent family members

International application No PCT/GB2010/050282
--

Patent document cited in search report	Publication date	Publication date	Patent family member(s)	Publication date
US 2005053465	A1	10-03-2005	NONE	
US 2009026850	A1	29-01-2009	NONE	
WO 2008014641	A1	07-02-2008	CN 201027677 Y CN 101313152 A	27-02-2008 26-11-2008
US 2808198	A	01-10-1957	NONE	
US 2004149881	A1	05-08-2004	NONE	
US 2336295	A	07-12-1943	NONE	