

(19) World Intellectual Property Organization  
International Bureau



(43) International Publication Date  
10 September 2010 (10.09.2010)

(10) International Publication Number  
**WO 2010/100455 A1**

(51) International Patent Classification:

F04F 5/16 (2006.01) F04D 25/08 (2006.01)  
F04F 5/46 (2006.01) F04D 27/02 (2006.01)

(21) International Application Number:

PCT/GB2010/050274

(22) International Filing Date:

18 February 2010 (18.02.2010)

(25) Filing Language:

English

(26) Publication Language:

English

(30) Priority Data:

0903693.0 4 March 2009 (04.03.2009) GB

(71) Applicant (for all designated States except US): **DYSON TECHNOLOGY LIMITED** [GB/GB]; Tetbury Hill, Malmesbury Wiltshire SN16 0RP (GB).

(72) Inventors; and

(75) Inventors/Applicants (for US only): **GAMMACK, Peter** [GB/GB]; Dyson Technology Limited, Tetbury Hill, Malmesbury Wiltshire SN16 0RP (GB). **DYSON, James** [GB/GB]; Dyson Technology Limited, Tetbury Hill, Malmesbury Wiltshire SN16 0RP (GB).

(74) Agents: **BOOTH, Andrew** et al.; Dyson Technology Limited, Intellectual Property Department, Tetbury Hill, Malmesbury Wiltshire SN16 0RP (GB).

(81) Designated States (unless otherwise indicated, for every kind of national protection available): AE, AG, AL, AM, AO, AT, AU, AZ, BA, BB, BG, BH, BR, BW, BY, BZ, CA, CH, CL, CN, CO, CR, CU, CZ, DE, DK, DM, DO, DZ, EC, EE, EG, ES, FI, GB, GD, GE, GH, GM, GT, HN, HR, HU, ID, IL, IN, IS, JP, KE, KG, KM, KN, KP, KR, KZ, LA, LC, LK, LR, LS, LT, LU, LY, MA, MD, ME, MG, MK, MN, MW, MX, MY, MZ, NA, NG, NI, NO, NZ, OM, PE, PG, PH, PL, PT, RO, RS, RU, SC, SD, SE, SG, SK, SL, SM, ST, SV, SY, TH, TJ, TM, TN, TR, TT, TZ, UA, UG, US, UZ, VC, VN, ZA, ZM, ZW.

(84) Designated States (unless otherwise indicated, for every kind of regional protection available): ARIPO (BW, GH, GM, KE, LS, MW, MZ, NA, SD, SL, SZ, TZ, UG, ZM, ZW), Eurasian (AM, AZ, BY, KG, KZ, MD, RU, TJ, TM), European (AT, BE, BG, CH, CY, CZ, DE, DK, EE, ES, FI, FR, GB, GR, HR, HU, IE, IS, IT, LT, LU, LV, MC, MK, MT, NL, NO, PL, PT, RO, SE, SI, SK, SM, TR), OAPI (BF, BJ, CF, CG, CI, CM, GA, GN, GQ, GW, ML, MR, NE, SN, TD, TG).

Published:

— with international search report (Art. 21(3))

(54) Title: A FAN ASSEMBLY

FIG. 2

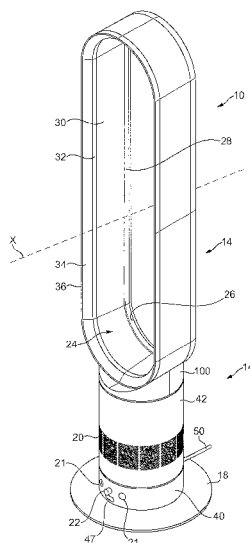

(57) Abstract: A fan assembly for creating an air current comprises an air inlet (20), an air outlet (14), an impeller (64) and a motor (68) for rotating the impeller to create an air flow passing from the air inlet to the air outlet. The air outlet (14) comprises an interior passage (94) for receiving the air flow and a mouth (26) for emitting the air flow. The air outlet defines an opening (24) through which air from outside the fan assembly is drawn by the air flow emitted from the mouth. The motor (68) has a rotor which, in use, is capable of rotating at a speed of at least 5,000 rpm.



WO 2010/100455 A1

### A Fan Assembly

The present invention relates to a fan assembly. In a preferred embodiment, the present invention relates to a domestic fan, such as a tower fan, for creating an air current in a room, office or other domestic environment.

A conventional domestic fan typically includes a set of blades or vanes mounted for rotation about an axis, and drive apparatus for rotating the set of blades to generate an air flow. The movement and circulation of the air flow creates a 'wind chill' or breeze and, as a result, the user experiences a cooling effect as heat is dissipated through convection and evaporation.

Such fans are available in a variety of sizes and shapes. For example, a ceiling fan can be at least 1 m in diameter, and is usually mounted in a suspended manner from the ceiling to provide a downward flow of air to cool a room. On the other hand, desk fans are often around 30 cm in diameter, and are usually free standing and portable. Floor-standing tower fans generally comprise an elongate, vertically extending casing around 1 m high and housing one or more sets of rotary blades for generating an air flow, usually in the range from 300 to 500 l/s. An oscillating mechanism may be employed to rotate the outlet from the tower fan so that the air flow is swept over a wide area of a room.

A disadvantage of this type of arrangement is that the air flow produced by the rotating blades of the fan is generally not uniform. This is due to variations across the blade surface or across the outward facing surface of the fan. The extent of these variations can vary from product to product and even from one individual fan machine to another. These variations result in the generation of an uneven or 'choppy' air flow which can be felt as a series of pulses of air and which can be uncomfortable for a user.

In a domestic environment it is desirable for appliances to be as small and compact as possible due to space restrictions. It is undesirable for parts of the appliance to project

outwardly, or for a user to be able to touch any moving parts, such as the blades. Many fans tend to have safety features such as a cage or shroud around the blades to prevent injury from the moving parts of the fan, but such caged parts can be difficult to clean.

5 The present invention provides a fan assembly for creating an air current, the fan assembly comprising an air inlet, an air outlet, an impeller and a motor for rotating the impeller to create an air flow passing from the air inlet to the air outlet, the air outlet comprising an interior passage for receiving the air flow and a mouth for emitting the air flow, the air outlet defining an opening through which air from outside the fan  
10 assembly is drawn by the air flow emitted from the mouth, wherein the motor has a rotor which, in use, is capable of rotating at a speed of at least 5,000 rpm.

With this fan assembly an air current can be generated and a cooling effect created without the use of a bladed fan. The air current created by the fan assembly has the  
15 benefit of being an air flow with low turbulence and with a more linear air flow profile than that provided by other prior art devices. This can improve the comfort of a user receiving the air flow. By providing a high speed motor to drive the impeller, the momentum of the air flow emitted through the mouth is not compromised by the channeling of the air flow into the interior passage, and the subsequent constriction of  
20 the air flow as it passes through the mouth.

Preferably, the rotor is capable of rotating at a speed of at least 8,000 rpm, more preferably at a speed of at least 9,000 rpm. The motor preferably comprises a DC brushless motor. This can avoid frictional losses and carbon debris from the brushes  
25 used in a traditional brushed motor. Reducing carbon debris and emissions is advantageous in a clean or pollutant sensitive environment such as a hospital or around those with allergies. While induction motors, which are generally used in bladed fans, also have no brushes, a DC brushless motor can provide a much wider range of operating speeds than an induction motor. The impeller is preferably a mixed flow  
30 impeller. The motor and the impeller are preferably located within a base of the fan assembly, the air outlet being preferably mounted on the base. The base preferably

comprises the air inlet, which may be located in a side wall of the base. For example, the air inlet of the base may comprise a grille comprising an array of apertures. The base preferably has an air outlet which is arranged to convey the air flow in a substantially vertical direction into the interior passage of the air outlet. The base is preferably cylindrical in shape, and preferably has a height in the range from 100 to 5  
300 mm. The fan assembly preferably has a height in the range from 400 to 1500 mm.

In the following description of fan assemblies, and, in particular a fan of the preferred embodiment, the term 'bladeless' is used to describe a fan assembly in which air flow is emitted or projected forward from the fan assembly without the use of moving blades. 10  
By this definition a bladeless fan assembly can be considered to have an output area or emission zone absent moving blades from which the air flow is directed towards a user or into a room. The output area of the bladeless fan assembly may be supplied with a primary air flow generated by one of a variety of different sources, such as pumps, 15  
generators, motors or other fluid transfer devices, and which may include a rotating device such as a motor rotor and/or a bladed impeller for generating the air flow. The generated primary air flow can pass from the room space or other environment outside the fan assembly through the interior passage to the mouth, and then back out to the room space through the mouth of the air outlet.

20  
Hence, the description of a fan assembly as bladeless is not intended to extend to the description of the power source and components such as motors that are required for secondary fan functions. Examples of secondary fan functions can include lighting, adjustment and oscillation of the fan assembly.

25  
The direction in which air is emitted from the mouth is preferably substantially at a right angle to the direction in which the air flow passes through at least part of the interior passage. In the preferred embodiment, the air flow passes through at least part of the interior passage in a substantially vertical direction, and the air is emitted from the 30  
mouth in a substantially horizontal direction. The interior passage is preferably located towards the front of the air outlet, whereas the mouth is preferably located towards the

rear of the air outlet and arranged to direct air towards the front of the air outlet and through the opening. Consequently, in the preferred embodiment the mouth is shaped so as substantially to reverse the flow direction of each portion of the air flow as it passes from the interior passage to an outlet of the mouth. The mouth is preferably  
5 substantially U-shaped in cross-section, and preferably narrows towards the outlet thereof.

The shape of the air outlet is not constrained by the requirement to include space for a bladed fan. Preferably, the air outlet comprises a nozzle, which preferably surrounds  
10 the opening. For example, the nozzle may extend about the opening by a distance in the range from 50 to 250 cm. In a preferred embodiment the air outlet is an elongate, annular nozzle which preferably has a height in the range from 500 to 1000 mm, and a width in the range from 100 to 300 mm. Alternatively, the air outlet may be substantially circular. The air outlet is preferably shaped to receive the air flow at one  
15 end thereof and to divide the air flow into two air streams, preferably with each air stream flowing along a respective elongate side of the opening.

The air outlet preferably comprises a casing, comprising an annular inner casing section and an annular outer casing section which define the interior passage, the mouth and the  
20 opening. Each casing section may comprise a plurality of components, but in the preferred embodiment each of these sections is formed from a single annular component. The outer casing section is preferably shaped so as to partially overlap the inner casing section to define at least one outlet of the mouth between overlapping portions of the external surface of the inner casing section and the internal surface of the  
25 outer casing section. The, or each, outlet is preferably in the form of a slot, preferably having a width in the range from 0.5 to 5 mm. Thus, the mouth preferably comprises a slot through which the air flow is emitted from the fan assembly. In the preferred embodiment, the mouth comprises a plurality of such outlets spaced about the opening. For example, one or more sealing members may be located within the mouth to define a  
30 plurality of spaced apart outlets. Preferably, the outlets are of substantially the same size. In the preferred embodiment in which the air outlet is in the form of an annular,

elongate nozzle, each outlet is preferably located along a respective elongate side of the inner periphery of the nozzle.

5 The air outlet may comprise a plurality of spacers for urging apart the overlapping portions of the inner casing section and the outer casing section. This can enable a substantially uniform outlet width to be achieved about the opening. The uniformity of the outlet width results in a relatively smooth, substantially even output of air from the mouth.

10 The air outlet may comprise a surface, preferably a Coanda surface, located adjacent the mouth and over which the mouth is arranged to direct the air flow emitted therefrom. In the preferred embodiment, the external surface of the inner casing section is shaped to define the Coanda surface. A Coanda surface is a known type of surface over which fluid flow exiting an output orifice close to the surface exhibits the Coanda effect. The  
15 fluid tends to flow over the surface closely, almost 'clinging to' or 'hugging' the surface. The Coanda effect is already a proven, well documented method of entrainment in which a primary air flow is directed over a Coanda surface. A description of the features of a Coanda surface, and the effect of fluid flow over a Coanda surface, can be found in articles such as Reba, Scientific American, Volume 214, June 1966 pages 84 to  
20 92. Through use of a Coanda surface, an increased amount of air from outside the fan assembly is drawn through the opening by the air emitted from the mouth.

In the preferred embodiment an air flow is created through the fan assembly. In the following description this air flow will be referred to as primary air flow. The primary  
25 air flow is emitted from the mouth and preferably passes over a Coanda surface. The primary air flow entrains air surrounding the mouth of the nozzle, which acts as an air amplifier to supply both the primary air flow and the entrained air to the user. The entrained air will be referred to here as a secondary air flow. The secondary air flow is drawn from the room space, region or external environment surrounding the mouth and,  
30 by displacement, from other regions around the fan assembly, and passes predominantly through the opening. The primary air flow directed over the Coanda surface combined

with the entrained secondary air flow equates to a total air flow emitted or projected forward from the opening. The total air flow is sufficient for the fan assembly to create an air current suitable for cooling. Preferably, the entrainment of air surrounding the mouth is such that the primary air flow is amplified by at least five times, more preferably by at least ten times, while a smooth overall output is maintained. Preferably, the air outlet comprises a diffuser located downstream of the Coanda surface. The diffuser directs the air flow emitted towards a user's location while maintaining a smooth, even output, generating a suitable cooling effect without the user feeling a 'choppy' flow.

10

Where the air outlet is in the form of an elongate nozzle, the nozzle may comprise a plurality of stationary guide vanes located within the interior passage and each for directing a portion of the air flow towards the mouth. The use of such guide vanes can assist in producing a substantially uniform distribution of the air flow through the mouth.

15

The air inlet of the base may comprise a grille comprising an array of apertures. The air outlet of the base is preferably arranged to convey the air flow in a substantially vertical direction into the nozzle. The base is preferably cylindrical in shape, and preferably has a height in the range from 100 to 300 mm. The fan assembly preferably has a height in the range from 400 to 1500 mm.

20

An embodiment of the present invention will now be described, by way of example only, with reference to the accompanying drawings, in which:

25

Figure 1 is a front view of a tower fan;

Figure 2 is a perspective view of the fan of Figure 1;

30

Figure 3 is a cross-sectional view of the base of the fan of Figure 1;

Figure 4 is an exploded view of the nozzle of the fan of Figure 1;

Figure 5 is an enlarged view of area A indicated in Figure 4;

5 Figure 6 is a front view of the nozzle of Figure 4;

Figure 7 is a sectional view of the nozzle taken along line E-E in Figure 6;

Figure 8 is a sectional view of the nozzle taken along line D-D in Figure 6;

10

Figure 9 is an enlarged view of a section of the nozzle illustrated in Figure 8;

Figure 10 is a sectional view of the nozzle taken along line C-C in Figure 6;

15 Figure 11 is an enlarged view of a section of the nozzle illustrated in Figure 10;

Figure 12 is a sectional view of the nozzle taken along line B-B in Figure 6;

Figure 13 is an enlarged view of a section of the nozzle illustrated in Figure 12; and

20

Figure 14 illustrates the air flow through part of the nozzle of the fan of Figure 1.

Figures 1 and 2 illustrate an embodiment of a bladeless fan assembly. In this embodiment, the bladeless fan assembly is in the form of a domestic, portable tower fan  
25 10 comprising a base 12 and an air outlet in the form of a nozzle 14 mounted on and supported by the base 12. The base 12 comprises a substantially cylindrical outer casing 16 mounted optionally on a disc-shaped base plate 18. The outer casing 16 comprises a plurality of air inlets 20 in the form of apertures formed in the outer casing 16 and through which a primary air flow is drawn into the base 12 from the external  
30 environment. The base 12 further comprises a plurality of user-operable buttons 21 and a user-operable dial 22 for controlling the operation of the fan 10. In this embodiment



the base 12 has a height in the range from 100 to 300 mm, and the outer casing 16 has a diameter in the range from 100 to 200 mm.

The nozzle 14 has an elongate, annular shape and defines a central elongate opening 24.

5 The nozzle 14 has a height in the range from 500 to 1200 mm, and a width in the range from 150 to 400 mm. In this example, the height of the nozzle is around 750 mm and the width of the nozzle is around 190 mm. The nozzle 14 comprises a mouth 26 located towards the rear of the fan 10 for emitting air from the fan 10 and through the opening 24. The mouth 26 extends at least partially about the opening 24. The inner periphery

10 of the nozzle 14 comprises a Coanda surface 28 located adjacent the mouth 26 and over which the mouth 26 directs the air emitted from the fan 10, a diffuser surface 30 located downstream of the Coanda surface 28 and a guide surface 32 located downstream of the diffuser surface 30. The diffuser surface 30 is arranged to taper away from the central axis X of the opening 24 in such a way so as to assist the flow of air emitted from the

15 fan 10. The angle subtended between the diffuser surface 30 and the central axis X of the opening 24 is in the range from 5 to 15°, and in this embodiment is around 7°. The guide surface 32 is arranged at an angle to the diffuser surface 30 to further assist the efficient delivery of a cooling air flow from the fan 10. In the illustrated embodiment the guide surface 32 is arranged substantially parallel to the central axis X of the

20 opening 24 to present a substantially flat and substantially smooth face to the air flow emitted from the mouth 26. A visually appealing tapered surface 34 is located downstream from the guide surface 32, terminating at a tip surface 36 lying substantially perpendicular to the central axis X of the opening 24. The angle subtended between the tapered surface 34 and the central axis X of the opening 24 is preferably

25 around 45°. The overall depth of the nozzle 24 in a direction extending along the central axis X of the opening 24 is in the range from 100 to 150 mm, and in this example is around 110 mm.

Figure 3 illustrates a sectional view through the base 12 of the fan 10. The outer casing

30 16 of the base 12 comprises a lower casing section 40 and a main casing section 42 mounted on the lower casing section 40. The lower casing section 40 houses a

controller, indicated generally at 44, for controlling the operation of the fan 10 in response to depression of the user operable buttons 21 shown in Figures 1 and 2, and/or manipulation of the user operable dial 22. The lower casing section 40 may optionally comprise a sensor 46 for receiving control signals from a remote control (not shown), and for conveying these control signals to the controller 44. These control signals are preferably infrared signals. The sensor 46 is located behind a window 47 through which the control signals enter the lower casing section 40 of the outer casing 16 of the base 12. A light emitting diode (not shown) may be provided for indicating whether the fan 10 is in a stand-by mode. The lower casing section 40 also houses a mechanism, indicated generally at 48, for oscillating the main casing section 42 relative to the lower casing section 40. The range of each oscillation cycle of the main casing section 42 relative to the lower casing section 40 is preferably between 60° and 120°, and in this embodiment is around 90°. In this embodiment, the oscillating mechanism 48 is arranged to perform around 3 to 5 oscillation cycles per minute. A mains power cable 50 extends through an aperture formed in the lower casing section 40 for supplying electrical power to the fan 10.

The main casing section 42 comprises a cylindrical grille 60 in which an array of apertures 62 is formed to provide the air inlets 20 of the outer casing 16 of the base 12. The main casing section 42 houses an impeller 64 for drawing the primary air flow through the apertures 62 and into the base 12. Preferably, the impeller 64 is in the form of a mixed flow impeller. The impeller 64 is connected to a rotary shaft 66 extending outwardly from a motor 68. In this embodiment, the motor 68 is a DC brushless motor having a speed which is variable by the controller 44 in response to user manipulation of the dial 22 and/or a signal received from the remote control. The maximum speed of the motor 68 is preferably in the range from 5,000 to 10,000 rpm. The motor 68 is housed within a motor bucket comprising an upper portion 70 connected to a lower portion 72. The upper portion 70 of the motor bucket comprises a diffuser 74 in the form of a stationary disc having spiral blades. The motor bucket is located within, and mounted on, a generally frusto-conical impeller housing 76 connected to the main casing section 42. The impeller 42 and the impeller housing 76 are shaped so that the

impeller 42 is in close proximity to, but does not contact, the inner surface of the impeller housing 76. A substantially annular inlet member 78 is connected to the bottom of the impeller housing 76 for guiding the primary air flow into the impeller housing 76. The impeller housing 76 is oriented so that the primary air flow is exhausted from the impeller housing 76 in a substantially vertical direction.

A profiled upper casing section 80 is connected to the open upper end of the main casing section 42 of the base 12, for example by means of snap-fit connections 82. An O-ring sealing member 84 is used to form an air-tight seal between the main casing section 42 and the upper casing section 80 of the base 12. The upper casing section 80 comprises a chamber 86 for receiving the primary air flow from the main casing section 42, and an aperture 88 through which the primary air flow passes from the base 12 into the nozzle 14.

Preferably, the base 12 further comprises silencing foam for reducing noise emissions from the base 12. In this embodiment, the main casing section 42 of the base 12 comprises a first, generally cylindrical foam member 89a located beneath the grille 60, a second, substantially annular foam member 89b located between the impeller housing 76 and the inlet member 78, and a third, substantially annular foam member 89c located within the motor bucket.

The nozzle 14 of the fan 10 will now be described with reference to Figures 4 to 13. The nozzle 14 comprises a casing comprising an elongate, annular outer casing section 90 connected to and extending about an elongate, annular inner casing section 92. The inner casing section 92 defines the central opening 24 of the nozzle 14, and has an external peripheral surface 93 which is shaped to define the Coanda surface 28, diffuser surface 30, guide surface 32 and tapered surface 34.

The outer casing section 90 and the inner casing section 92 together define an annular interior passage 94 of the nozzle 14. The interior passage 94 is located towards the front of the fan 10. The interior passage 94 extends about the opening 24, and thus

comprises two substantially vertically extending sections each adjacent a respective elongate side of the central opening 24, an upper curved section joining the upper ends of the vertically extending sections, and a lower curved section joining the lower ends of the vertically extending sections. The interior passage 94 is bounded by the internal peripheral surface 96 of the outer casing section 90 and the internal peripheral surface 98 of the inner casing section 92. The outer casing section 90 comprises a base 100 which is connected to, and over, the upper casing section 80 of the base 12, for example by a snap-fit connection. The base 100 of the outer casing section 90 comprises an aperture 102 which is aligned with the aperture 88 of the upper casing section 80 of the base 12 and through which the primary air flow enters the lower curved portion of the interior passage 94 of the nozzle 14 from the base 12 of the fan 10.

With particular reference to Figures 8 and 9, the mouth 26 of the nozzle 14 is located towards the rear of the fan 10. The mouth 26 is defined by overlapping, or facing, portions 104, 106 of the internal peripheral surface 96 of the outer casing section 90 and the external peripheral surface 93 of the inner casing section 92, respectively. In this embodiment, the mouth 26 comprises two sections each extending along a respective elongate side of the central opening 24 of the nozzle 14, and in fluid communication with a respective vertically extending section of the interior passage 94 of the nozzle 14. The air flow through each section of the mouth 26 is substantially orthogonal to the air flow through the respective vertically extending portion of the interior passage 94 of the nozzle 14. Each section of the mouth 26 is substantially U-shaped in cross-section, and so as a result the direction of the air flow is substantially reversed as the air flow passes through the mouth 26. In this embodiment, the overlapping portions 104, 106 of the internal peripheral surface 96 of the outer casing section 90 and the external peripheral surface 93 of the inner casing section 92 are shaped so that each section of the mouth 26 comprises a tapering portion 108 narrowing to an outlet 110. Each outlet 110 is in the form of a substantially vertically extending slot, preferably having a relatively constant width in the range from 0.5 to 5 mm. In this embodiment each outlet 110 has a width of around 1.1 mm.

The mouth 26 may thus be considered to comprise two outlets 110 each located on a respective side of the central opening 24. Returning to Figure 4, the nozzle 14 further comprises two curved seal members 112, 114 each for forming a seal between the outer casing section 90 and the inner casing section 92 so that there is substantially no leakage  
5 of air from the curved sections of the interior passage 94 of the nozzle 14.

In order to direct the primary air flow into the mouth 26, the nozzle 14 comprises a plurality of stationary guide vanes 120 located within the interior passage 94 and each for directing a portion of the air flow towards the mouth 26. The guide vanes 120 are  
10 illustrated in Figures 4, 5, 7, 10 and 11. The guide vanes 120 are preferably integral with the internal peripheral surface 98 of the inner casing section 92 of the nozzle 14. The guide vanes 120 are curved so that there is no significant loss in the velocity of the air flow as it is directed into the mouth 26. In this embodiment the nozzle 14 comprises  
15 two sets of guide vanes 120, with each set of guide vanes 120 directing air passing along a respective vertically extending portion of the interior passage 94 towards its associated section of the mouth 26. Within each set, the guide vanes 120 are substantially vertically aligned and evenly spaced apart to define a plurality of passageways 122 between the guide vanes 120 and through which air is directed into  
20 the mouth 26. The even spacing of the guide vanes 120 provides a substantially even distribution of the air stream along the length of the section of the mouth 26.

With reference to Figure 11, the guide vanes 120 are preferably shaped so that a portion 124 of each guide vane 120 engages the internal peripheral surface 96 of the outer casing section 90 of the nozzle 24 so as to urge apart the overlapping portions 104, 106  
25 of the internal peripheral surface 96 of the outer casing section 90 and the external peripheral surface 93 of the inner casing section 92. This can assist in maintaining the width of each outlet 110 at a substantially constant level along the length of each section of the mouth 26. With reference to Figures 7, 12 and 13, in this embodiment additional spacers 126 are provided along the length of each section of the mouth 26, also for  
30 urging apart the overlapping portions 104, 106 of the internal peripheral surface 96 of the outer casing section 90 and the external peripheral surface 93 of the inner casing

section 92, to maintain the width of the outlet 110 at the desired level. Each spacer 126 is located substantially midway between two adjacent guide vanes 120. To facilitate manufacture the spacers 126 are preferably integral with the external peripheral surface 98 of the inner casing section 92 of the nozzle 14. Additional spacers 126 may be provided between adjacent guide vanes 120 if so desired.

In use, when the user depresses an appropriate one of the buttons 21 on the base 12 of the fan 10 the controller 44 activates the motor 68 to rotate the impeller 64, which causes a primary air flow to be drawn into the base 12 of the fan 10 through the air inlets 20. The primary air flow may be up to 30 litres per second, more preferably up to 50 litres per second. The primary air flow passes through the impeller housing 76 and the upper casing section 80 of the base 12, and enters the base 100 of the outer casing section 90 of the nozzle 14, from which the primary air flow enters the interior passage 94 of the nozzle 14.

With reference also to Figure 14 the primary air flow, indicated at 148, is divided into two air streams, one of which is indicated at 150 in Figure 14, which pass in opposite directions around the central opening 24 of the nozzle 14. Each air stream 150 enters a respective one of the two vertically extending sections of the interior passage 94 of the nozzle 14, and is conveyed in a substantially vertical direction up through each of these sections of the interior passage 94. The set of guide vanes 120 located within each of these sections of the interior passage 94 directs the air stream 150 towards the section of the mouth 26 located adjacent that vertically extending section of the interior passage 94. Each of the guide vanes 120 directs a respective portion 152 of the air stream 150 towards the section of the mouth 26 so that there is a substantially uniform distribution of the air stream 150 along the length of the section of the mouth 26. The guide vanes 120 are shaped so that each portion 152 of the air stream 150 enters the mouth 26 in a substantially horizontal direction. Within each section of the mouth 26, the flow direction of the portion of the air stream is substantially reversed, as indicated at 154 in Figure 14. The portion of the air stream is constricted as the section of the mouth 26

tapers towards the outlet 110 thereof, channeled around the spacer 126 and emitted through the outlet 110, again in a substantially horizontal direction.

5 The primary air flow emitted from the mouth 26 is directed over the Coanda surface 28 of the nozzle 14, causing a secondary air flow to be generated by the entrainment of air from the external environment, specifically from the region around the outlets 110 of the mouth 26 and from around the rear of the nozzle 14. This secondary air flow passes predominantly through the central opening 24 of the nozzle 14, where it combines with the primary air flow to produce a total air flow 156, or air current, projected forward  
10 from the nozzle 14.

The even distribution of the primary air flow along the mouth 26 of the nozzle 14 ensures that the air flow passes evenly over the diffuser surface 30. The diffuser surface 30 causes the mean speed of the air flow to be reduced by moving the air flow through a  
15 region of controlled expansion. The relatively shallow angle of the diffuser surface 30 to the central axis X of the opening 24 allows the expansion of the air flow to occur gradually. A harsh or rapid divergence would otherwise cause the air flow to become disrupted, generating vortices in the expansion region. Such vortices can lead to an increase in turbulence and associated noise in the air flow, which can be undesirable,  
20 particularly in a domestic product such as a fan. In the absence of the guide vanes 120 most of the primary air flow would tend to leave the fan 10 through the upper part of the mouth 26, and to leave the mouth 26 upwardly at an acute angle to the central axis of the opening 24. As a result there would be an uneven distribution of air within the air current generated by the fan 10. Furthermore, most of the air flow from the fan 10  
25 would not be properly diffused by the diffuser surface 30, leading to the generation of an air current with much greater turbulence.

The air flow projected forwards beyond the diffuser surface 30 can tend to continue to diverge. The presence of the guide surface 32 extending substantially parallel to the  
30 central axis X of the opening 30 tends to focus the air flow towards the user or into a room.

Depending on the speed of the motor 64, the mass flow rate of the air current projected forward from the fan 10 may be up to 500 litres per second, and in the preferred embodiment is up to 700 litres per second, and the maximum speed of the air current  
5 may be in the range from 3 to 4 m/s.

The invention is not limited to the detailed description given above. Variations will be apparent to the person skilled in the art.

10 For example, the base and the nozzle of the fan may be of a different shape and/or shape. The outlet of the mouth may be modified. For example, the outlet of the mouth may be widened or narrowed to a variety of spacings to maximise air flow. The air flow emitted from the mouth may pass over a surface, such as Coanda surface, but  
15 alternatively the air flow may be emitted through the mouth and projected forward from the fan without passing over an adjacent surface. The Coanda effect may be effected over a number of different surfaces, or a number of internal or external designs may be used in combination to achieve the flow and entrainment required. The diffuser surface may be comprised of a variety of diffuser lengths and structures. The guide surface may be a variety of lengths, and may be arranged at a number of different positions and  
20 orientations as required for different fan requirements and different types of fan performance. Additional features such as lighting or a clock or LCD display may be provided within the central opening defined by the nozzle.



**CLAIMS**

1. A fan assembly for creating an air current, the fan assembly comprising an air inlet, an air outlet, an impeller and a motor for rotating the impeller to create an air flow passing from the air inlet to the air outlet, the air outlet comprising an interior passage for receiving the air flow and a mouth for emitting the air flow, the air outlet defining an opening through which air from outside the fan assembly is drawn by the air flow emitted from the mouth, wherein the motor has a rotor which, in use, is capable of rotating at a speed of at least 5,000 rpm.
2. A fan assembly as claimed in claim 1, wherein the rotor is capable of rotating at a speed of at least 8,000 rpm.
3. A fan assembly as claimed in claim 1 or claim 2, wherein the rotor is capable of rotating at a speed of at least 9,000 rpm.
4. A fan assembly as claimed in any of the preceding claims, comprising a base housing the impeller and the motor.
5. A fan assembly as claimed in claim 4, wherein said air inlet is located in a side wall of the base.
6. A fan assembly as claimed in any of the preceding claims, wherein the interior passage is shaped to divide the air flow into two air streams and to direct each air stream along a respective side of the opening.
7. A fan assembly as claimed in any of the preceding claims, wherein the air outlet comprises an annular inner casing section and an annular outer casing section which together define the interior passage and the mouth.

8. A fan assembly as claimed in claim 7, wherein the mouth comprises an outlet located between an external surface of the inner casing section and an internal surface of the outer casing section.
- 5 9. A fan assembly as claimed in claim 8, wherein the outlet is in the form of a slot.
10. A fan assembly as claimed in claim 8 or claim 9, wherein the outlet has a width in the range from 0.5 to 5 mm.
- 10 11. A fan assembly as claimed in any of the preceding claims, wherein the air outlet comprises a surface located adjacent the mouth and over which the mouth is arranged to direct the air flow.
12. A fan assembly as claimed in claim 11, wherein the surface is a Coanda surface.
- 15 13. A fan assembly as claimed in claim 11 or claim 12, wherein the air outlet comprises a diffuser located downstream of the Coanda surface.
14. A fan assembly as claimed in any of the preceding claims, wherein the motor is
- 20 a DC brushless motor.
15. A fan assembly as claimed in any of the preceding claims, wherein the fan assembly has a height in the range from 400 to 1500 mm.
- 25 16. A fan assembly or a fan substantially as hereinbefore described with reference to the accompanying drawings.

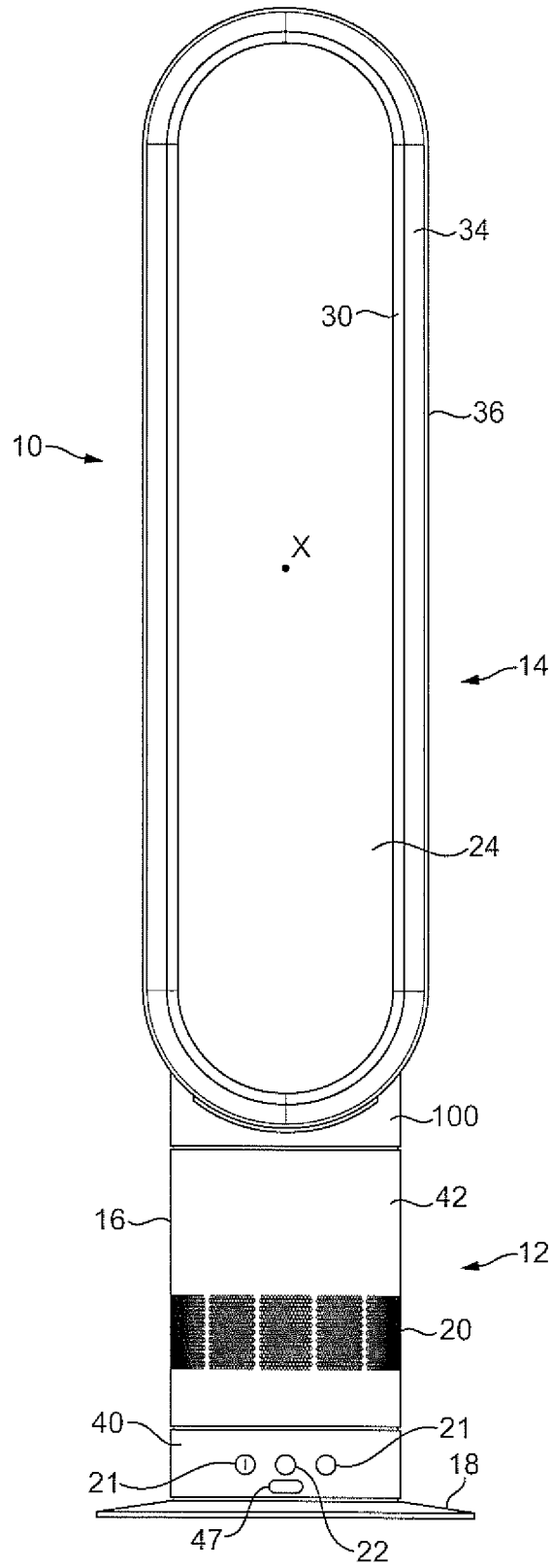

FIG. 1

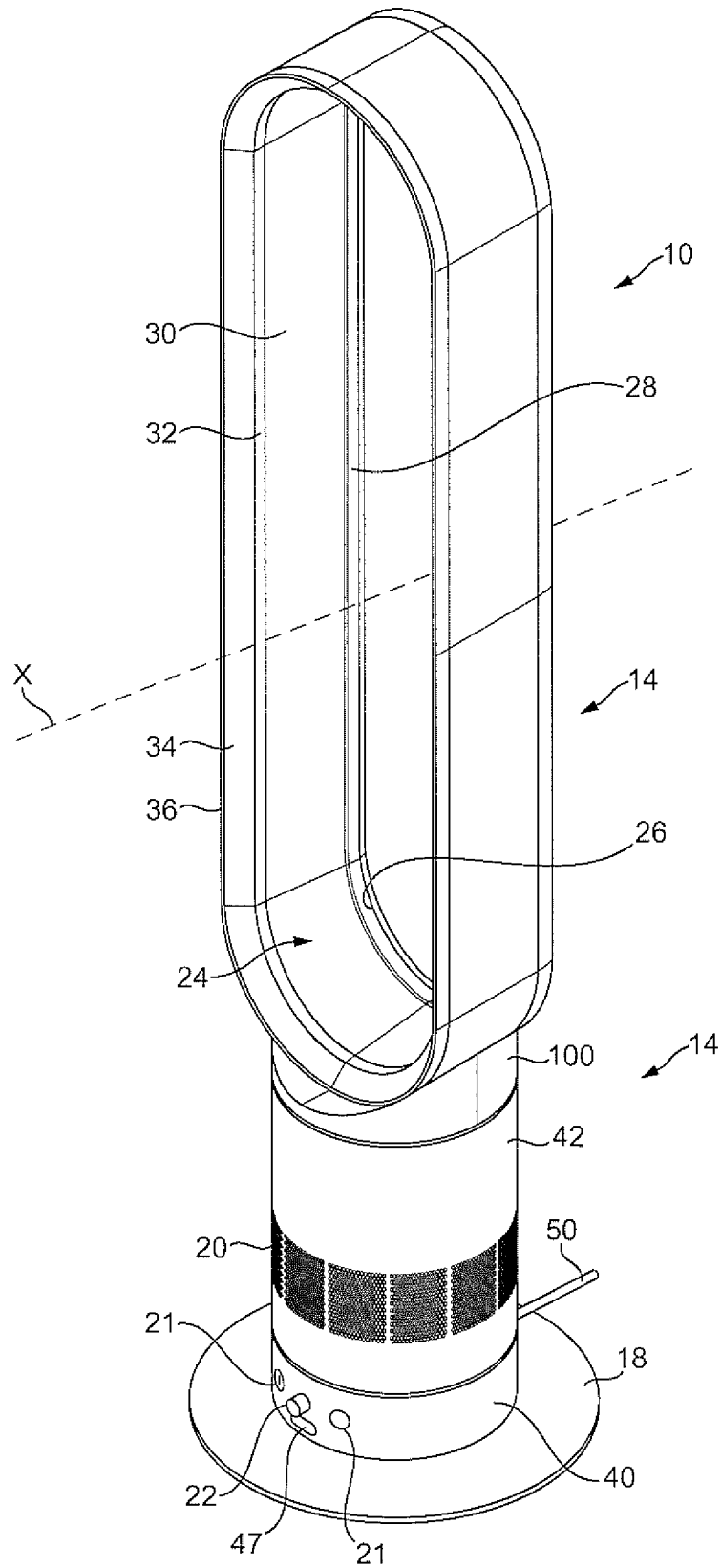

FIG. 2

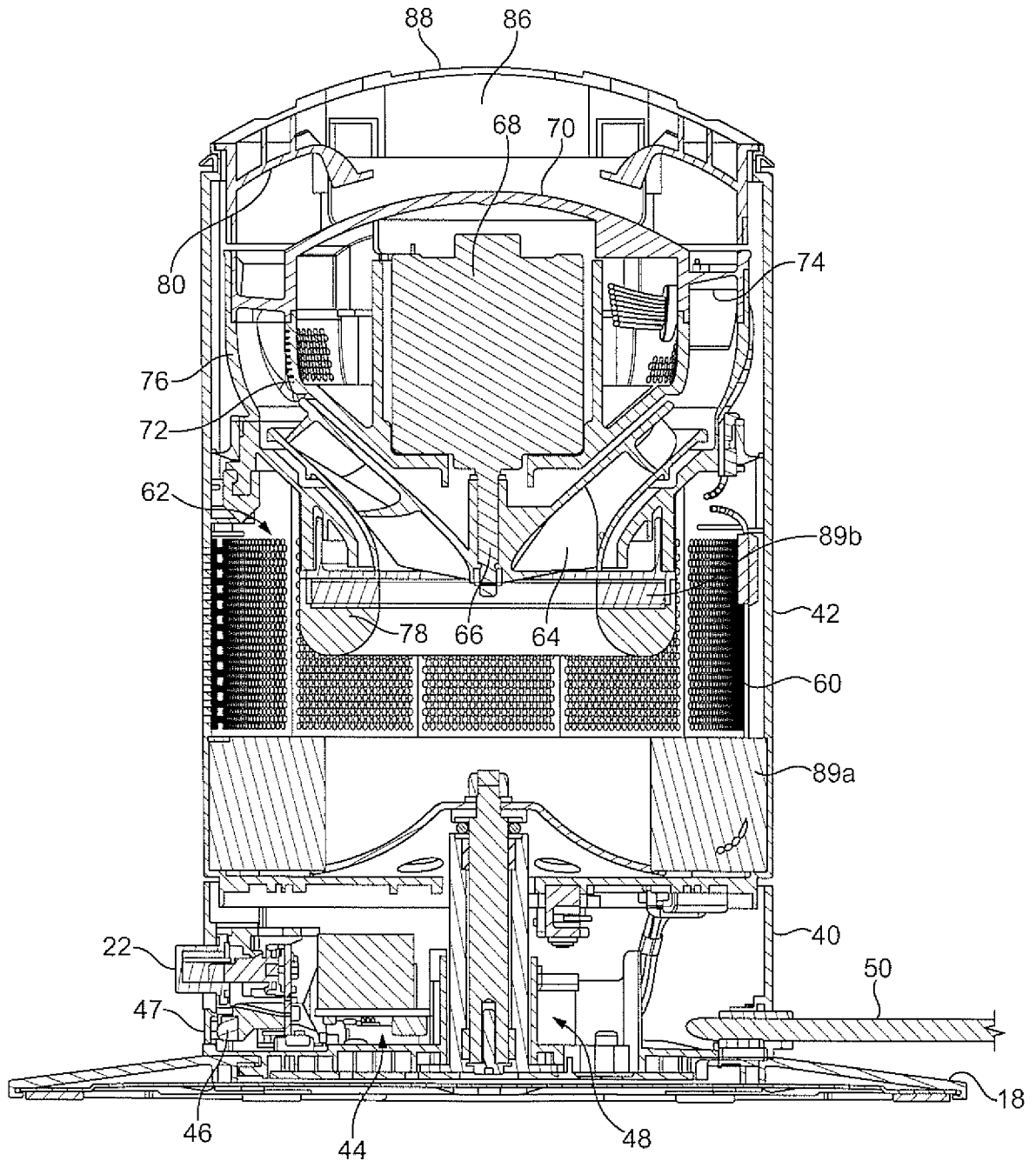

FIG. 3

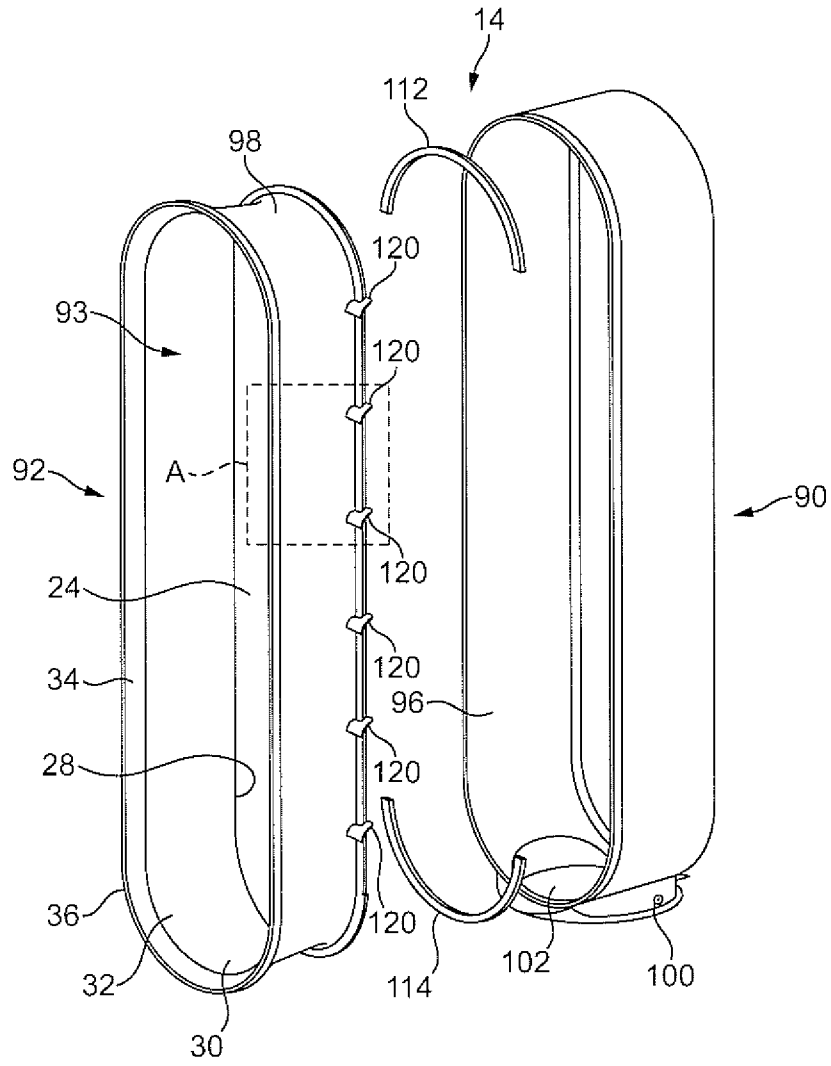

FIG. 4

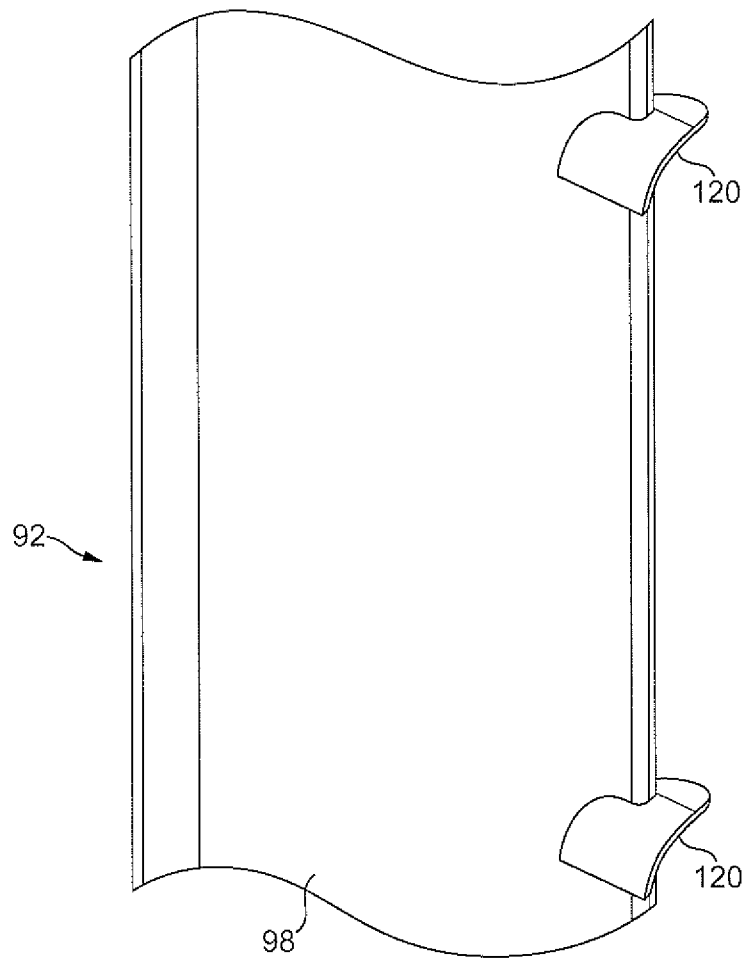

FIG. 5

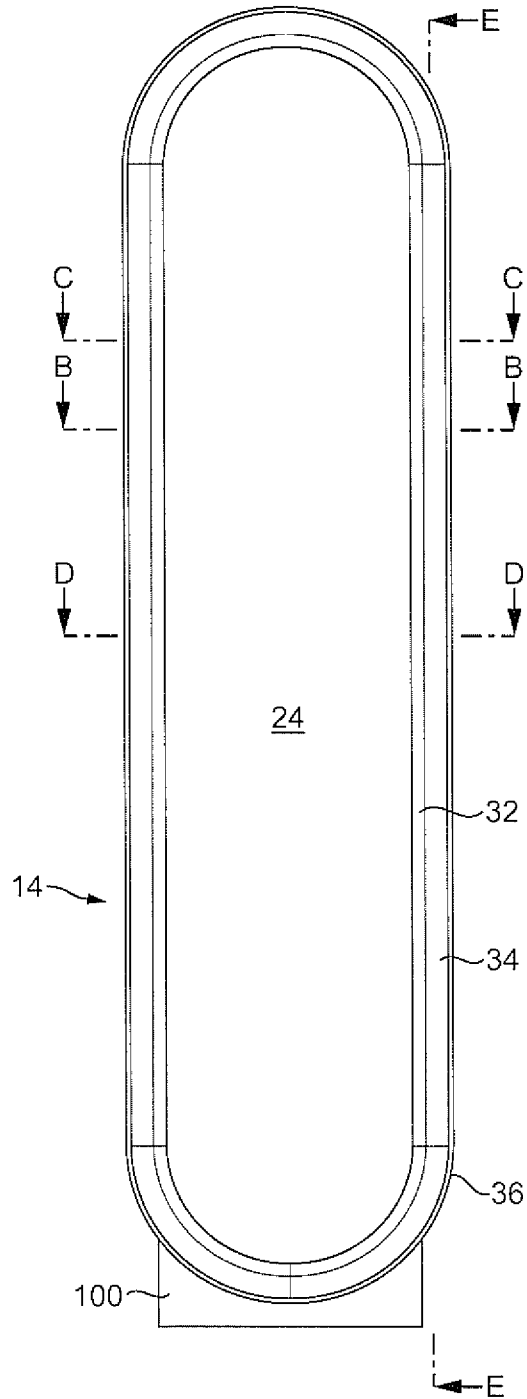

FIG. 6

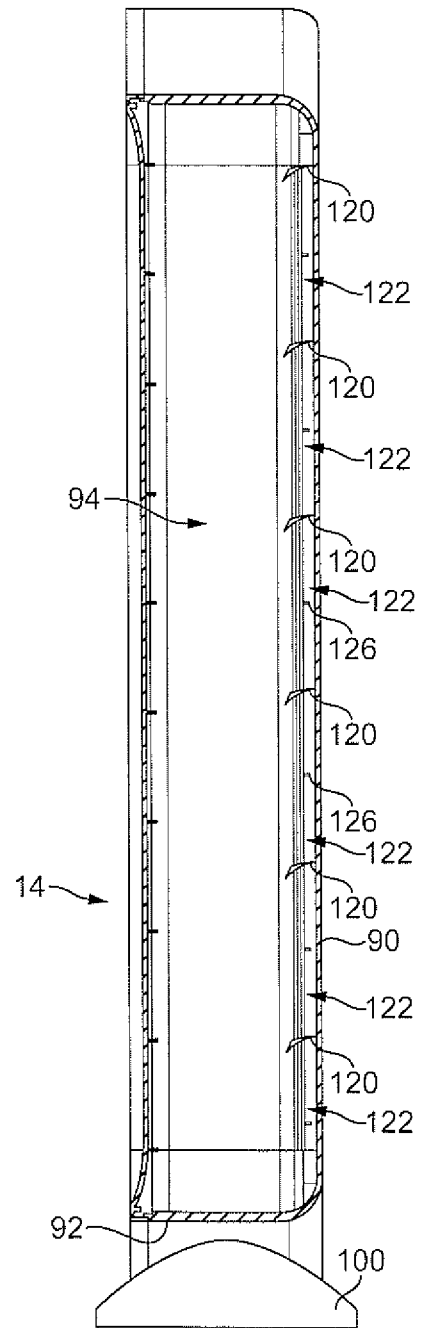

FIG. 7





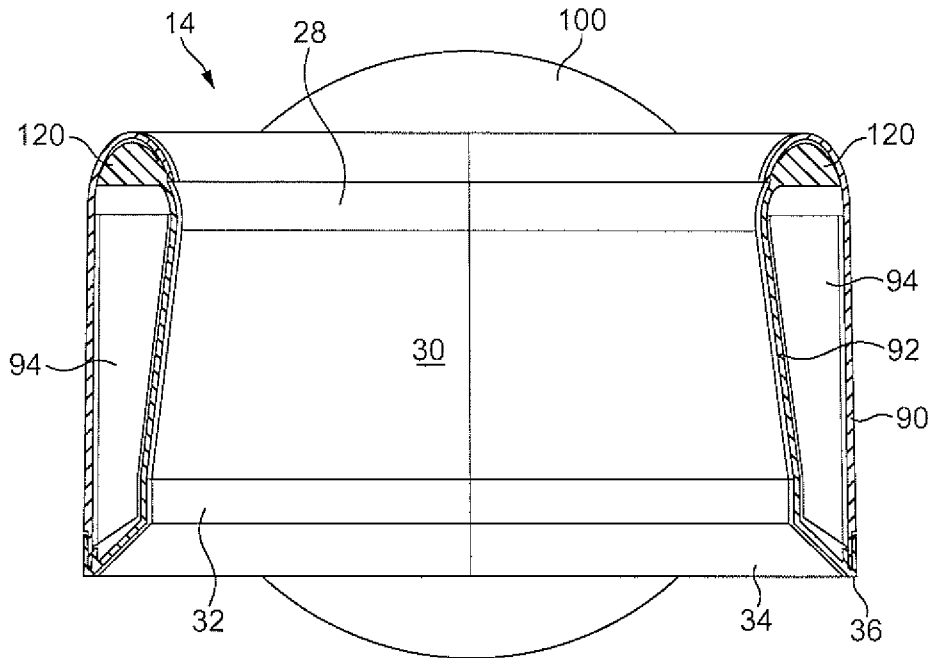

FIG. 10

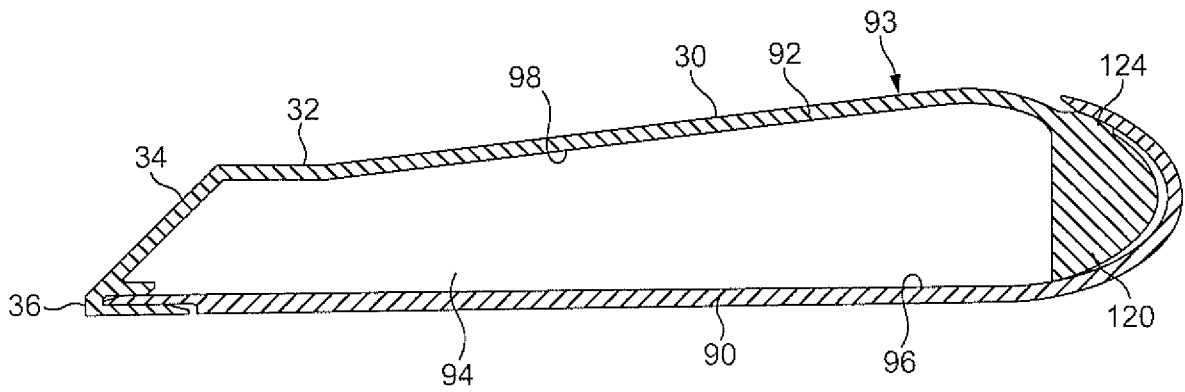

FIG. 11

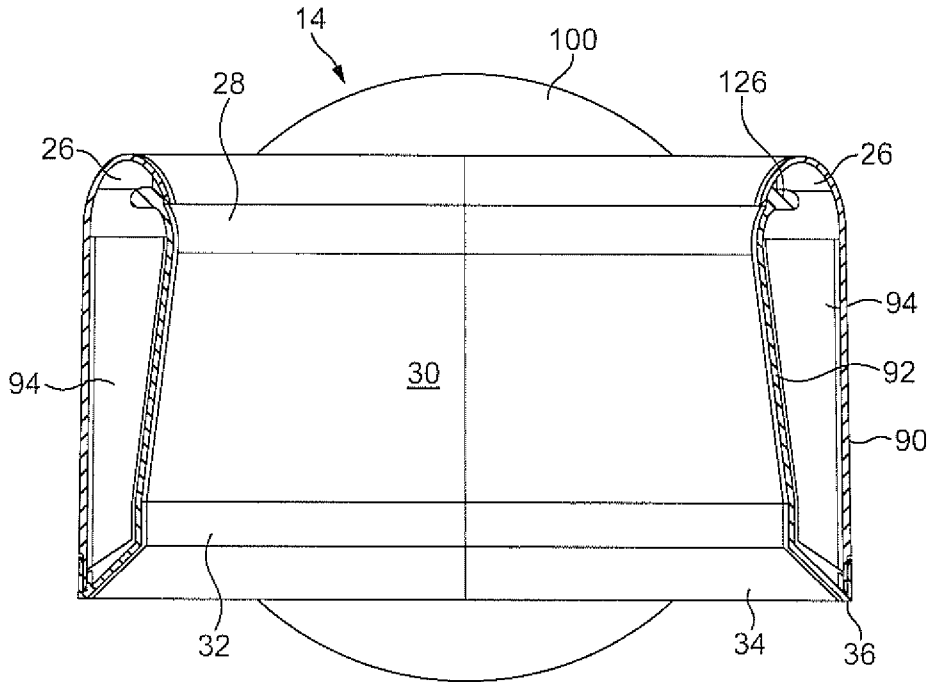

FIG. 12

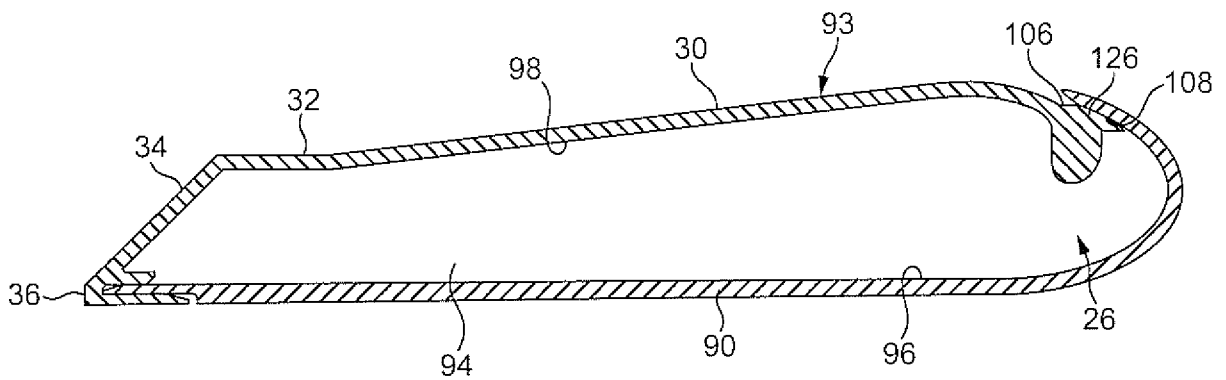

FIG. 13

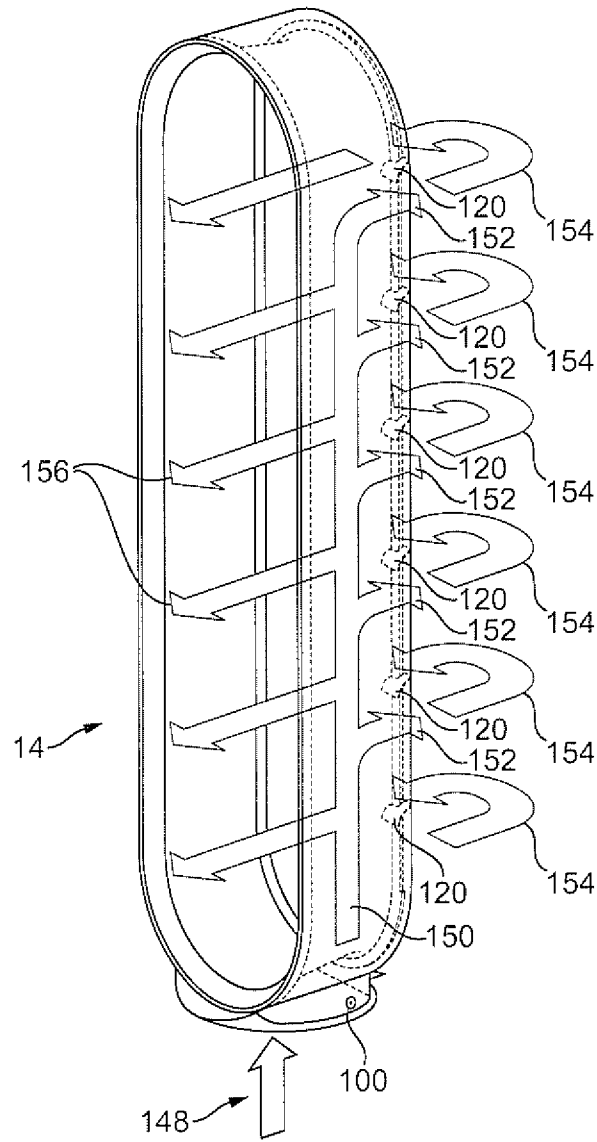

FIG. 14

# INTERNATIONAL SEARCH REPORT

International application No  
PCT/GB2010/050274

<b>A. CLASSIFICATION OF SUBJECT MATTER</b> INV. F04F5/16      F04F5/46      F04D25/08      F04D27/02 ADD.		
According to International Patent Classification (IPC) or to both national classification and IPC		
<b>B. FIELDS SEARCHED</b> Minimum documentation searched (classification system followed by classification symbols) F04F F04D		
Documentation searched other than minimum documentation to the extent that such documents are included in the fields searched		
Electronic data base consulted during the international search (name of data base and, where practical, search terms used) EPO-Internal, PAJ, WPI Data		
<b>C. DOCUMENTS CONSIDERED TO BE RELEVANT</b>		
Category*	Citation of document, with indication, where appropriate, of the relevant passages	Relevant to claim No.
Y	JP 56 167897 A (TOKYO SHIBAURA ELECTRIC CO) 23 December 1981 (1981-12-23) abstract; figures 1,2	1-4,6-9, 11,12
Y	EP 1 138 954 A1 (TECHNOFAN [FR]) 4 October 2001 (2001-10-04) paragraph [0012] - paragraph [0016]; claim 1; figures 1-3	1-4,6-9, 11-14
Y	JP 2000 116179 A (CALSONIC CORP) 21 April 2000 (2000-04-21)	14
A	abstract; figures 1,2	1
Y	US 2 488 467 A (DE LISIO SALVATORE) 15 November 1949 (1949-11-15)	13
A	column 1, line 18 - column 2, line 21; figures 1,2	1,4,6, 9-12,15
----- -/--		
<input checked="" type="checkbox"/> Further documents are listed in the continuation of Box C.		
<input checked="" type="checkbox"/> See patent family annex.		
* Special categories of cited documents :		
"A" document defining the general state of the art which is not considered to be of particular relevance	"T" later document published after the international filing date or priority date and not in conflict with the application but cited to understand the principle or theory underlying the invention	
"E" earlier document but published on or after the international filing date	"X" document of particular relevance; the claimed invention cannot be considered novel or cannot be considered to involve an inventive step when the document is taken alone	
"L" document which may throw doubts on priority claim(s) or which is cited to establish the publication date of another citation or other special reason (as specified)	"Y" document of particular relevance; the claimed invention cannot be considered to involve an inventive step when the document is combined with one or more other such documents, such combination being obvious to a person skilled in the art.	
"O" document referring to an oral disclosure, use, exhibition or other means	"&" document member of the same patent family	
"P" document published prior to the international filing date but later than the priority date claimed		
Date of the actual completion of the international search  <p style="text-align: center; font-weight: bold;">21 April 2010</p>	Date of mailing of the international search report  <p style="text-align: center; font-weight: bold;">18/05/2010</p>	
Name and mailing address of the ISA/ European Patent Office, P.B. 5818 Patentlaan 2 NL - 2280 HV Rijswijk Tel. (+31-70) 340-2040, Fax: (+31-70) 340-3016	Authorized officer  <p style="text-align: center; font-weight: bold;">Di Giorgio, F</p>	

## INTERNATIONAL SEARCH REPORT

International application No  
PCT/GB2010/050274

## C(Continuation). DOCUMENTS CONSIDERED TO BE RELEVANT

Category*	Citation of document, with indication, where appropriate, of the relevant passages	Relevant to claim No.
A	US 6 123 618 A (DAY TERENCE ROBERT [AU]) 26 September 2000 (2000-09-26) column 4, line 3 - column 5, line 52; figure 5	1,4, 11-13
A	DE 12 91 090 B (SCHMIDT GEB HALM ANNELIESE) 20 March 1969 (1969-03-20) column 2, line 27 - line 52; figures 1,2	1,6,9, 11-13
A	US 5 881 685 A (FOSS JOHN F [US] ET AL) 16 March 1999 (1999-03-16) column 6, line 19 - line 11; figures 6-8	1,6,9, 11-13
A	IMANTS REBA: "Applications of the Coanda effect" SCIENTIFIC AMERICAN, June 1966 (1966-06), pages 84-92, XP009132496 cited in the application the whole document	1,12,13

# INTERNATIONAL SEARCH REPORT

Information on patent family members

International application No PCT/GB2010/050274
---

Patent document cited in search report	A	Publication date	Patent family member(s)	Publication date
JP 56167897	A	23-12-1981	NONE	
EP 1138954	A1	04-10-2001	AT 452294 T EP 2151584 A1 FR 2807117 A1	15-01-2010 10-02-2010 05-10-2001
JP 2000116179	A	21-04-2000	JP 4173587 B2	29-10-2008
US 2488467	A	15-11-1949	NONE	
US 6123618	A	26-09-2000	NONE	
DE 1291090	B	20-03-1969	NONE	
US 5881685	A	16-03-1999	AT 280896 T DE 69731337 D1 EP 0820557 A1 JP 11502586 T WO 9726450 A1 US 5762034 A	15-11-2004 02-12-2004 28-01-1998 02-03-1999 24-07-1997 09-06-1998