

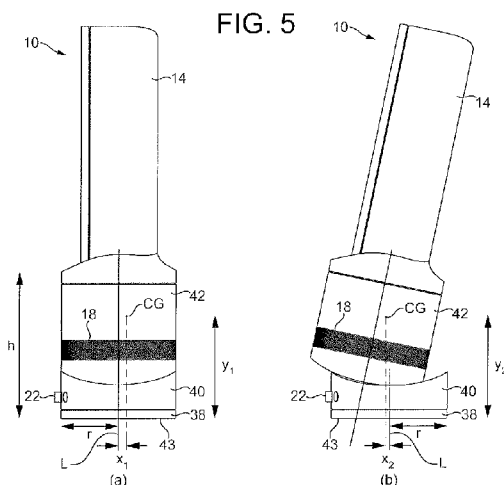

- (51) **International Patent Classification:**
F04D 25/10 (2006.01) F04F 5/46 (2006.01)
F04F 5/16 (2006.01)
- (21) **International Application Number:**
PCT/GB2010/050268
- (22) **International Filing Date:**
18 February 2010 (18.02.2010)
- (25) **Filing Language:** English
- (26) **Publication Language:** English
- (30) **Priority Data:**
0903674.0 4 March 2009 (04.03.2009) GB
- (71) **Applicant (for all designated States except US):** DYSON TECHNOLOGY LIMITED [GB/GB]; Tetbury Hill, Malmesbury Wiltshire SN16 0RP (GB).
- (72) **Inventor; and**
- (75) **Inventor/Applicant (for US only):** GAMMACK, Peter [GB/GB]; c/o Dyson Technology Limited, Tetbury Hill, Malmesbury Wiltshire SN16 0RP (GB).
- (74) **Agents:** BOOTH, Andrew et al.; Dyson Technology Limited, Intellectual Property Department, Tetbury Hill, Malmesbury Wiltshire SN16 0RP (GB).
- (81) **Designated States (unless otherwise indicated, for every kind of national protection available):** AE, AG, AL, AM, AO, AT, AU, AZ, BA, BB, BG, BH, BR, BW, BY, BZ, CA, CH, CL, CN, CO, CR, CU, CZ, DE, DK, DM, DO, DZ, EC, EE, EG, ES, FI, GB, GD, GE, GH, GM, GT, HN, HR, HU, ID, IL, IN, IS, JP, KE, KG, KM, KN, KP, KR, KZ, LA, LC, LK, LR, LS, LT, LU, LY, MA, MD, ME, MG, MK, MN, MW, MX, MY, MZ, NA, NG, NI, NO, NZ, OM, PE, PG, PH, PL, PT, RO, RS, RU, SC, SD, SE, SG, SK, SL, SM, ST, SV, SY, TH, TJ, TM, TN, TR, TT, TZ, UA, UG, US, UZ, VC, VN, ZA, ZM, ZW.
- (84) **Designated States (unless otherwise indicated, for every kind of regional protection available):** ARIPO (BW, GH, GM, KE, LS, MW, MZ, NA, SD, SL, SZ, TZ, UG, ZM, ZW), Eurasian (AM, AZ, BY, KG, KZ, MD, RU, TJ, TM), European (AT, BE, BG, CH, CY, CZ, DE, DK, EE, ES, FI, FR, GB, GR, HR, HU, IE, IS, IT, LT, LU, LV, MC, MK, MT, NL, NO, PL, PT, RO, SE, SI, SK, SM, TR), OAPI (BF, BJ, CF, CG, CI, CM, GA, GN, GQ, GW, ML, MR, NE, SN, TD, TG).
- Published:**
— with international search report (Art. 21(3))

(54) Title: A FAN ASSEMBLY



(57) **Abstract:** A fan assembly for creating an air current comprises an air outlet (14) mounted on a stand (12). The stand (12) comprises a base (38, 40) and a body (42) tiltable relative to the base (38, 40). The fan assembly has a centre of gravity (CG) located so that when the base is located on a substantially horizontal support surface, the projection of the centre of gravity on the support surface is within the footprint of the base when the body is in a fully tilted position.

A Fan Assembly

The present invention relates to a fan assembly. Particularly, but not exclusively, the present invention relates to a domestic fan, such as a desk fan, for creating air circulation and air current in a room, in an office or other domestic environment.

A conventional domestic fan typically includes a set of blades or vanes mounted for rotation about an axis, and drive apparatus for rotating the set of blades to generate an air flow. The movement and circulation of the air flow creates a 'wind chill' or breeze and, as a result, the user experiences a cooling effect as heat is dissipated through convection and evaporation.

Such fans are available in a variety of sizes and shapes. For example, a ceiling fan can be at least 1 m in diameter, and is usually mounted in a suspended manner from the ceiling to provide a downward flow of air to cool a room. On the other hand, desk fans are often around 30 cm in diameter, and are usually free standing and portable. Other types of fan can be attached to the floor or mounted on a wall. Fans such as that disclosed in USD 103,476 and US 1,767,060 are suitable for standing on a desk or a table.

A disadvantage of this type of fan is that the air flow produced by the rotating blades is generally not uniform. This is due to variations across the blade surface or across the outward facing surface of the fan. The extent of these variations can vary from product to product and even from one individual fan machine to another. These variations result in the generation of an uneven or 'choppy' air flow which can be felt as a series of pulses of air and which can be uncomfortable for a user. A further disadvantage is that the cooling effect created by the fan diminishes with distance from the user. This means that the fan must be placed in close proximity to the user in order for the user to experience the cooling effect of the fan.

An oscillating mechanism may be employed to rotate the outlet from the fan so that the air flow is swept over a wide area of a room. The oscillating mechanism can lead to some improvement in the quality and uniformity of the air flow felt by a user although the characteristic 'choppy' air flow remains.

5

Locating fans such as those described above close to a user is not always possible as the bulky shape and structure of the fan mean that the fan occupies a significant amount of the user's work space area.

10 Some fans, such as that described in US 5,609,473, provide a user with an option to adjust the direction in which air is emitted from the fan. In US 5,609,473, the fan comprises a base and a pair of yokes each upstanding from a respective end of the base. The outer body of the fan houses a motor and a set of rotating blades. The outer body is secured to the yokes so as to be pivotable relative to the base. The fan body may be
15 swung relative to the base from a generally vertical, untilted position to an inclined, tilted position. In this way the direction of the air flow emitted from the fan can be altered.

In such fans, a securing mechanism may be employed to fix the position of the body of
20 the fan relative to the base. The securing mechanism may comprise a clamp or manual locking screws which may be difficult to use, particularly for the elderly or for users with impaired dexterity.

In a domestic environment it is desirable for appliances to be as small and compact as
25 possible due to space restrictions. In contrast, fan adjustment mechanisms are often bulky, and are mounted to, and often extend from, the outer surface of the fan assembly. When such a fan is placed on a desk, the footprint of the adjustment mechanism can undesirably reduce the area available for paperwork, a computer or other office equipment. In addition, it is undesirable for parts of the appliance to project outwardly,
30 both for safety reasons and because such parts can be difficult to clean.

In a first aspect the present invention provides a fan assembly for creating an air current, the fan assembly comprising a stand and an air outlet mounted on the stand for emitting an air flow, the stand comprising a base and a body tiltable relative to the base from an untilted position to a tilted position, the body comprising means for creating said air
5 flow, the fan assembly having a centre of gravity located so that when the base is located on a substantially horizontal support surface, the projection of the centre of gravity on the support surface is within the footprint of the base when the body is in a fully tilted position.

10 The weight of the components of the means for creating said air flow can act to stabilise the body on the base when the body is in a tilted position. The centre of gravity of the fan assembly is preferably located within the body. Preferably the means for creating said air flow comprises an impeller, a motor for rotating the impeller, and preferably also a diffuser located downstream from the impeller. The impeller is preferably a
15 mixed flow impeller. The motor is preferably a DC brushless motor to avoid frictional losses and carbon debris from the brushes used in a traditional brushed motor. Reducing carbon debris and emissions is advantageous in a clean or pollutant sensitive environment such as a hospital or around those with allergies. While induction motors, which are generally used in pedestal fans, also have no brushes, a DC brushless motor
20 can provide a much wider range of operating speeds than an induction motor.

The body preferably comprises at least one air inlet through which air is drawn into the fan assembly by the means for creating said air flow. This can provide a short, compact air flow path that minimises noise and frictional losses.

25

The projection of the centre of gravity on the support surface may be behind the centre of the base with respect to a forward direction of the fan assembly when the body is in an untilted position.

30 Each of the base and the body preferably has an outer surface shaped so that adjoining portions of the outer surfaces are substantially flush when the body is in the untilted

position. This can provide the stand with a tidy and uniform appearance when in an untilted position. This type of uncluttered appearance is desirable and often appeals to a user or customer. The flush portions also have the benefit of allowing the outer surfaces of the base and the body to be quickly and easily wiped clean. The outer surfaces of the
5 base and the body are preferably substantially cylindrical. In the preferred embodiment the stand is substantially cylindrical.

Preferably the base has a substantially circular footprint having a radius r , and a longitudinal axis passing centrally therethrough. Preferably the centre of gravity of the
10 fan assembly is spaced by a radial distance of no more than $0.8r$, more preferably no more than $0.6r$ and preferably no more than $0.4r$, from the longitudinal axis when the body is in a fully tilted position. This can provide the fan assembly with increased stability.

15 Preferably, the base comprising a plurality of rolling elements for supporting the body, the body comprising a plurality of curved races for receiving the rolling elements and within which the rolling elements move as the body is moved from an untilted position to a tilted position. The curved races of the body are preferably convex in shape. Preferably the base comprises a plurality of support members each comprising a
20 respective one of the rolling elements. The support surfaces preferably protrude from a curved, preferably concave, surface of the base of the stand.

The stand preferably comprises interlocking means for retaining the body on the base. The interlocking means are preferably enclosed by the outer surfaces of the base and the
25 body when the body is in the untilted position so that the stand retains its tidy and uniform appearance.

The stand preferably comprises means for urging the interlocking means together to resist movement of the body from the tilted position. The base preferably comprises a
30 plurality of support members for supporting the body, and which are preferably also enclosed by the outer surfaces of the base and the body when the body is in the untilted

position. Each support member preferably comprises a rolling element for supporting the body, the body comprising a plurality of curved races for receiving the rolling elements and within which the rolling elements move as the body is moved from an untilted position to a tilted position.

5

The interlocking means preferably comprises a first plurality of locking members located on the base, and a second plurality of locking members located on the body and which are retained by the first plurality of locking members. Each of the locking members is preferably substantially L-shaped. The interlocking members preferably
10 comprise interlocking flanges, which are preferably curved. The curvature of the flanges of the interlocking members of the base is preferably substantially the same as the curvature of the flanges of the interlocking members of the body. This can maximise the frictional forces generated between the interlocking flanges which act against the movement of the body from the tilted position.

15

The stand preferably comprises means for inhibiting the movement of the body relative to the base beyond a fully tilted position. The movement inhibiting means preferably comprises a stop member depending from the body for engaging part of the base when the body is in a fully tilted position. In the preferred embodiment the stop member is
20 arranged to engage part of the interlocking means, preferably a flange of an interlocking member of the base, to inhibit movement of the body relative to the base beyond the fully tilted position

The base preferably comprises control means for controlling the fan assembly. For
25 safety reasons and ease of use, it can be advantageous to locate control elements away from the tiltable body so that the control functions, such as, for example, oscillation, lighting or activation of a speed setting, are not activated during a tilt operation.

The fan assembly is preferably in the form of a bladeless fan assembly. Through use of
30 a bladeless fan assembly an air current can be generated without the use of a bladed fan. Without the use of a bladed fan to project the air current from the fan assembly, a

relatively uniform air current can be generated and guided into a room or towards a user. The air current can travel efficiently out from the outlet, losing little energy and velocity to turbulence.

5 The term 'bladeless' is used to describe a fan assembly in which air flow is emitted or projected forward from the fan assembly without the use of moving blades. Consequently, a bladeless fan assembly can be considered to have an output area, or emission zone, absent moving blades from which the air flow is directed towards a user or into a room. The output area of the bladeless fan assembly may be supplied with a
10 primary air flow generated by one of a variety of different sources, such as pumps, generators, motors or other fluid transfer devices, and which may include a rotating device such as a motor rotor and/or a bladed impeller for generating the air flow. The generated primary air flow can pass from the room space or other environment outside the fan assembly into the fan assembly, and then back out to the room space through the
15 outlet.

Hence, the description of a fan assembly as bladeless is not intended to extend to the description of the power source and components such as motors that are required for secondary fan functions. Examples of secondary fan functions can include lighting,
20 adjustment and oscillation of the fan assembly.

The air outlet preferably comprises a nozzle mounted on the stand, the nozzle comprising a mouth for emitting the air flow, the nozzle extending about an opening through which air from outside the nozzle is drawn by the air flow emitted from the
25 mouth. Preferably, the nozzle surrounds the opening. The nozzle may be an annular nozzle which preferably has a height in the range from 200 to 600 mm, more preferably in the range from 250 to 500 mm.

Preferably, the mouth of the nozzle extends about the opening, and is preferably
30 annular. The nozzle preferably comprises an inner casing section and an outer casing section which define the mouth of the nozzle. Each section is preferably formed from a

respective annular member, but each section may be provided by a plurality of members connected together or otherwise assembled to form that section. The outer casing section is preferably shaped so as to partially overlap the inner casing section. This can enable an outlet of the mouth to be defined between overlapping portions of the external
5 surface of the inner casing section and the internal surface of the outer casing section of the nozzle. The outlet is preferably in the form of a slot, preferably having a width in the range from 0.5 to 5 mm, more preferably in the range from 0.5 to 1.5 mm. The nozzle may comprise a plurality of spacers for urging apart the overlapping portions of the inner casing section and the outer casing section of the nozzle. This can assist in
10 maintaining a substantially uniform outlet width about the opening. The spacers are preferably evenly spaced along the outlet.

The nozzle preferably comprises an interior passage for receiving the air flow from the stand. The interior passage is preferably annular, and is preferably shaped to divide the
15 air flow into two air streams which flow in opposite directions around the opening. The interior passage is preferably also defined by the inner casing section and the outer casing section of the nozzle.

The fan assembly preferably comprises means for oscillating the nozzle so that the air
20 current is swept over an arc, preferably in the range from 60 to 120°. For example, the base of the stand may comprise means for oscillating an upper base member, to which the body is connected, relative to a lower base member.

The maximum air flow of the air current generated by the fan assembly is preferably in
25 the range from 300 to 800 litres per second, more preferably in the range from 500 to 800 litres per second.

The nozzle may comprise a surface, preferably a Coanda surface, located adjacent the
30 mouth and over which the mouth is arranged to direct the air flow emitted therefrom. Preferably, the external surface of the inner casing section of the nozzle is shaped to define the Coanda surface. The Coanda surface preferably extends about the opening.

A Coanda surface is a known type of surface over which fluid flow exiting an output orifice close to the surface exhibits the Coanda effect. The fluid tends to flow over the surface closely, almost 'clinging to' or 'hugging' the surface. The Coanda effect is already a proven, well documented method of entrainment in which a primary air flow is directed over a Coanda surface. A description of the features of a Coanda surface, and the effect of fluid flow over a Coanda surface, can be found in articles such as Reba, Scientific American, Volume 214, June 1966 pages 84 to 92. Through use of a Coanda surface, an increased amount of air from outside the fan assembly is drawn through the opening by the air emitted from the mouth.

10

Preferably, an air flow enters the nozzle of the fan assembly from the stand. In the following description this air flow will be referred to as primary air flow. The primary air flow is emitted from the mouth of the nozzle and preferably passes over a Coanda surface. The primary air flow entrains air surrounding the mouth of the nozzle, which acts as an air amplifier to supply both the primary air flow and the entrained air to the user. The entrained air will be referred to here as a secondary air flow. The secondary air flow is drawn from the room space, region or external environment surrounding the mouth of the nozzle and, by displacement, from other regions around the fan assembly, and passes predominantly through the opening defined by the nozzle. The primary air flow directed over the Coanda surface combined with the entrained secondary air flow equates to a total air flow emitted or projected forward from the opening defined by the nozzle. Preferably, the entrainment of air surrounding the mouth of the nozzle is such that the primary air flow is amplified by at least five times, more preferably by at least ten times, while a smooth overall output is maintained.

25

Preferably, the nozzle comprises a diffuser surface located downstream of the Coanda surface. The external surface of the inner casing section of the nozzle is preferably shaped to define the diffuser surface.

30

In a second aspect the present invention provides a fan assembly for creating an air current, the fan assembly comprising an air outlet mounted on a stand comprising a base

and a body tiltable relative to the base from an untilted position to a tilted position, the air outlet comprising a nozzle mounted on the stand, the nozzle comprising a mouth for emitting the air flow, the nozzle extending about an opening through which air from outside the nozzle is drawn by the air flow emitted from the mouth, the fan assembly
5 having a centre of gravity located so that when the base is located on a substantially horizontal support surface, the projection of the centre of gravity on the support surface is within the footprint of the base when the body is in a fully tilted position.

Features described above in relation to the first aspect of the invention are equally
10 applicable to the second aspect of the invention, and vice versa.

An embodiment of the invention will now be described with reference to the accompanying drawings, in which:

15 Figure 1 is a front view of a fan assembly;

Figure 2 is a perspective view of the nozzle of the fan assembly of Figure 1;

Figure 3 is a sectional view through the fan assembly of Figure 1;

20

Figure 4 is an enlarged view of part of Figure 3;

Figure 5(a) is a side view of the fan assembly of Figure 1 showing the fan assembly in an untilted position;

25

Figure 5(b) is a side view of the fan assembly of Figure 1 showing the fan assembly in a first tilted position;

Figure 5(c) is a side view of the fan assembly of Figure 1 showing the fan assembly in a
30 second tilted position;

Figure 6 is a top perspective view of the upper base member of the fan assembly of Figure 1;

Figure 7 is a rear perspective view of the main body of the fan assembly of Figure 1;

5

Figure 8 is an exploded view of the main body of Figure 7;

Figure 9(a) illustrates the paths of two sectional views through the stand when the fan assembly is in an untilted position;

10

Figure 9(b) is a sectional view along line A-A of Figure 9(a);

Figure 9(c) is a sectional view along line B-B of Figure 9(a);

15 Figure 10(a) illustrates the paths of two further sectional views through the stand when the fan assembly is in an untilted position;

Figure 10(b) is a sectional view along line C-C of Figure 10(a); and

20 Figure 10(c) is a sectional view along line D-D of Figure 10(a);

Figure 1 is a front view of a fan assembly 10. The fan assembly 10 is preferably in the form of a bladeless fan assembly comprising a stand 12 and a nozzle 14 mounted on and supported by the stand 12. The stand 12 comprises a substantially cylindrical outer casing 16 having a plurality of air inlets 18 in the form of apertures located in the outer casing 16 and through which a primary air flow is drawn into the stand 12 from the external environment. The stand 12 further comprises a plurality of user-operable buttons 20 and a user-operable dial 22 for controlling the operation of the fan assembly 10. The stand 12 preferably has a height in the range from 200 to 300 mm, and the outer casing 16 preferably has an external diameter in the range from 100 to 200 mm.

30

In this example, the stand 12 has a height h of around 190 mm, and an external diameter $2r$ of around 145 mm.

With reference also to Figure 2, the nozzle 14 has an annular shape and defines a central opening 24. The nozzle 14 has a height in the range from 200 to 400 mm. The nozzle 14 comprises a mouth 26 located towards the rear of the fan assembly 10 for emitting air from the fan assembly 10 and through the opening 24. The mouth 26 extends at least partially about the opening 24. The inner periphery of the nozzle 14 comprises a Coanda surface 28 located adjacent the mouth 26 and over which the mouth 26 directs the air emitted from the fan assembly 10, a diffuser surface 30 located downstream of the Coanda surface 28 and a guide surface 32 located downstream of the diffuser surface 30. The diffuser surface 30 is arranged to taper away from the central axis X of the opening 24 in such a way so as to assist the flow of air emitted from the fan assembly 10. The angle subtended between the diffuser surface 30 and the central axis X of the opening 24 is in the range from 5 to 25°, and in this example is around 15°. The guide surface 32 is arranged at an angle to the diffuser surface 30 to further assist the efficient delivery of a cooling air flow from the fan assembly 10. The guide surface 32 is preferably arranged substantially parallel to the central axis X of the opening 24 to present a substantially flat and substantially smooth face to the air flow emitted from the mouth 26. A visually appealing tapered surface 34 is located downstream from the guide surface 32, terminating at a tip surface 36 lying substantially perpendicular to the central axis X of the opening 24. The angle subtended between the tapered surface 34 and the central axis X of the opening 24 is preferably around 45°. The overall depth of the nozzle 24 in a direction extending along the central axis X of the opening 24 is in the range from 100 to 150 mm, and in this example is around 110 mm.

Figure 3 illustrates a sectional view through the fan assembly 10. The stand 12 comprises a base formed from a lower base member 38 and an upper base member 40 mounted on the lower base member 38, and a main body 42 mounted on the base. The lower base member 38 has a substantially flat, substantially circular bottom surface 43 for engaging a support surface upon which the fan assembly 10 is located. Due to the

cylindrical nature of the base, the footprint of the base is the same size as the bottom surface 43 of the lower base member 38, and so the footprint of the base has a radius r . The upper base member 40 houses a controller 44 for controlling the operation of the fan assembly 10 in response to depression of the user operable buttons 20 shown in
5 Figures 1 and 2, and/or manipulation of the user operable dial 22. The upper base member 40 may also house an oscillating mechanism 46 for oscillating the upper base member 40 and the main body 42 relative to the lower base member 38. The range of each oscillation cycle of the main body 42 is preferably between 60° and 120° , and in this example is around 90° . In this example, the oscillating mechanism 46 is arranged
10 to perform around 3 to 5 oscillation cycles per minute. A mains power cable 48 extends through an aperture formed in the lower base member 38 for supplying electrical power to the fan assembly 10.

The main body 42 of the stand 12 has an open upper end to which the nozzle 14 is
15 connected, for example by a snap-fit connection. The main body 42 comprises a cylindrical grille 50 in which an array of apertures is formed to provide the air inlets 18 of the stand 12. The main body 42 houses an impeller 52 for drawing the primary air flow through the apertures of the grille 50 and into the stand 12. Preferably, the impeller 52 is in the form of a mixed flow impeller. The impeller 52 is connected to a
20 rotary shaft 54 extending outwardly from a motor 56. In this example, the motor 56 is a DC brushless motor having a speed which is variable by the controller 44 in response to user manipulation of the dial 22. The maximum speed of the motor 56 is preferably in the range from 5,000 to 10,000 rpm. The motor 56 is housed within a motor bucket comprising an upper portion 58 connected to a lower portion 60. One of the upper
25 portion 58 and the lower portion 60 of the motor bucket comprises a diffuser 62 in the form of a stationary disc having spiral blades, and which is located downstream from the impeller 52.

The motor bucket is located within, and mounted on, an impeller housing 64. The
30 impeller housing 64 is, in turn, mounted on a plurality of angularly spaced supports 66, in this example three supports, located within the main body 42 of the stand 12. A

generally frusto-conical shroud 68 is located within the impeller housing 64. The shroud 68 is shaped so that the outer edges of the impeller 52 are in close proximity to, but do not contact, the inner surface of the shroud 68. A substantially annular inlet member 70 is connected to the bottom of the impeller housing 64 for guiding the primary air flow into the impeller housing 64. Preferably, the stand 12 further comprises silencing foam for reducing noise emissions from the stand 12. In this example, the main body 42 of the stand 12 comprises a disc-shaped foam member 72 located towards the base of the main body 42, and a substantially annular foam member 74 located within the motor bucket.

10

Figure 4 illustrates a sectional view through the nozzle 14. The nozzle 14 comprises an annular outer casing section 80 connected to and extending about an annular inner casing section 82. Each of these sections may be formed from a plurality of connected parts, but in this embodiment each of the outer casing section 80 and the inner casing section 82 is formed from a respective, single moulded part. The inner casing section 82 defines the central opening 24 of the nozzle 14, and has an external peripheral surface 84 which is shaped to define the Coanda surface 28, diffuser surface 30, guide surface 32 and tapered surface 34.

15

The outer casing section 80 and the inner casing section 82 together define an annular interior passage 86 of the nozzle 14. Thus, the interior passage 86 extends about the opening 24. The interior passage 86 is bounded by the internal peripheral surface 88 of the outer casing section 80 and the internal peripheral surface 90 of the inner casing section 82. The outer casing section 80 comprises a base 92 which is connected to, and over, the open upper end of the main body 42 of the stand 12, for example by a snap-fit connection. The base 92 of the outer casing section 80 comprises an aperture through which the primary air flow enters the interior passage 86 of the nozzle 14 from the open upper end of the main body 42 of the stand 12.

25

The mouth 26 of the nozzle 14 is located towards the rear of the fan assembly 10. The mouth 26 is defined by overlapping, or facing, portions 94, 96 of the internal peripheral

30

surface 88 of the outer casing section 80 and the external peripheral surface 84 of the inner casing section 82, respectively. In this example, the mouth 26 is substantially annular and, as illustrated in Figure 4, has a substantially U-shaped cross-section when sectioned along a line passing diametrically through the nozzle 14. In this example, the overlapping portions 94, 96 of the internal peripheral surface 88 of the outer casing section 80 and the external peripheral surface 84 of the inner casing section 82 are shaped so that the mouth 26 tapers towards an outlet 98 arranged to direct the primary flow over the Coanda surface 28. The outlet 98 is in the form of an annular slot, preferably having a relatively constant width in the range from 0.5 to 5 mm. In this example the outlet 98 has a width of around 1.1 mm. Spacers may be spaced about the mouth 26 for urging apart the overlapping portions 94, 96 of the internal peripheral surface 88 of the outer casing section 80 and the external peripheral surface 84 of the inner casing section 82 to maintain the width of the outlet 98 at the desired level. These spacers may be integral with either the internal peripheral surface 88 of the outer casing section 80 or the external peripheral surface 84 of the inner casing section 82.

Turning now to Figures 5(a), 5(b) and 5(c), the main body 42 is moveable relative to the base of the stand 12 between a first fully tilted position, as illustrated in Figure 5(b), and a second fully tilted position, as illustrated in Figure 5(c). This axis X is preferably inclined by an angle of around 10° as the main body 42 is moved from an untilted position, as illustrated in Figure 5(a) to one of the two fully tilted positions. The outer surfaces of the main body 42 and the upper base member 40 are shaped so that adjoining portions of these outer surfaces of the main body 42 and the base are substantially flush when the main body 42 is in the untilted position.

25

The centre of gravity of the fan assembly is identified at CG in Figures 5(a), 5(b) and 5(c). The centre of gravity CG is located within the main body 42 of the stand 12. When the lower base member 38 of the stand 12 is located on a horizontal support surface, the projection of the centre of gravity CG on the support surface is within the footprint of the base, irrespective of the position of the main body 42 between the first

30

and second fully tilted positions, so that the fan assembly 10 is in a stable configuration irrespective of the position of the main body 42.

5 With reference to Figure 5(a), when the main body 42 is in the untitled position the projection of the centre of gravity CG on the support surface lies behind the centre of the base with respect to a forward direction of the fan assembly, which is from right to left as viewed in Figures 5(a), 5(b) and 5(c). In this example, the radial distance x_1 between the longitudinal axis L of the base and the centre of gravity CG is around $0.15r$, where r is the radius of the bottom surface 43 of the lower base member 38, and the
10 distance y_1 along the longitudinal axis L between the bottom surface 43 and the centre of gravity is around $0.7h$, where h is the height of the stand 12. When the main body 42 is in the first fully titled position illustrated in Figure 5(b) the projection of the centre of gravity CG on the support surface lies slightly in front of the centre of the base. In this
15 example, the radial distance x_2 between the longitudinal axis L of the base and the centre of gravity CG is around $0.05r$, while the distance y_2 along the longitudinal axis L between the bottom surface 43 and the centre of gravity remains around $0.7h$. When the main body 42 is in the second fully titled position illustrated in Figure 5(c), the projection of the centre of gravity CG on the support surface lies behind the centre of the base. In this example, the radial distance x_3 between the longitudinal axis L of the
20 base and the centre of gravity CG is around $0.35r$, while the distance y_3 along the longitudinal axis L between the bottom surface 43 and the centre of gravity remains around $0.7h$. The difference between y_2 and y_3 is preferably no more than 5 mm, more preferably no more than 2 mm.

25 With reference to Figure 6, the upper base member 40 comprises an annular lower surface 100 which is mounted on the lower base member 38, a substantially cylindrical side wall 102 and a curved upper surface 104. The side wall 102 comprises a plurality of apertures 106. The user-operable dial 22 protrudes through one of the apertures 106 whereas the user-operable buttons 20 are accessible through the other apertures 106.
30 The curved upper surface 104 of the upper base member 40 is concave in shape, and may be described as generally saddle-shaped. An aperture 108 is formed in the upper

surface 104 of the upper base member 40 for receiving an electrical cable 110 (shown in Figure 3) extending from the motor 56.

The upper base member 40 further comprises four support members 120 for supporting
5 the main body 42 on the upper base member 40. The support members 120 project upwardly from the upper surface 104 of the upper base member 40, and are arranged such that they are substantially equidistant from each other, and substantially equidistant from the centre of the upper surface 104. A first pair of the support members 120 is located along the line B-B indicated in Figure 9(a), and a second pair of the support
10 members 120 is parallel with the first pair of support members 120. With reference also to Figures 9(b) and 9(c), each support member 120 comprises a cylindrical outer wall 122, an open upper end 124 and a closed lower end 126. The outer wall 122 of the support member 120 surrounds a rolling element 128 in the form of a ball bearing. The rolling element 128 preferably has a radius which is slightly smaller than the radius of
15 the cylindrical outer wall 122 so that the rolling element 128 is retained by and moveable within the support member 120. The rolling element 128 is urged away from the upper surface 104 of the upper base member 40 by a resilient element 130 located between the closed lower end 126 of the support member 120 and the rolling element 128 so that part of the rolling element 128 protrudes beyond the open upper end 124 of
20 the support member 120. In this embodiment, the resilient member 130 is in the form of a coiled spring.

Returning to Figure 6, the upper base member 40 also comprises a plurality of rails for retaining the main body 42 on the upper base member 40. The rails also serve to guide
25 the movement of the main body 42 relative to the upper base member 40 so that there is substantially no twisting or rotation of the main body 42 relative to the upper base member 40 as it is moved from or to a tilted position. Each of the rails extends in a direction substantially parallel to the axis X. For example, one of the rails lies along line D-D indicated in Figure 10(a). In this embodiment, the plurality of rails comprises
30 a pair of relatively long, inner rails 140 located between a pair of relatively short, outer rails 142. With reference also to Figures 9(b) and 10(b), each of the inner rails 140 has

a cross-section in the form of an inverted L-shape, and comprises a wall 144 which extends between a respective pair of the support members 120, and which is connected to, and upstanding from, the upper surface 104 of the upper base member 40. Each of the inner rails 140 further comprises a curved flange 146 which extends along the length of the wall 144, and which protrudes orthogonally from the top of the wall 144 towards the adjacent outer guide rail 142. Each of the outer rails 142 also has a cross-section in the form of an inverted L-shape, and comprises a wall 148 which is connected to, and upstanding from, the upper surface 52 of the upper base member 40 and a curved flange 150 which extends along the length of the wall 148, and which protrudes orthogonally from the top of the wall 148 away from the adjacent inner guide rail 140.

With reference now to Figures 7 and 8, the main body 42 comprises a substantially cylindrical side wall 160, an annular lower end 162 and a curved base 164 which is spaced from lower end 162 of the main body 42 to define a recess. The grille 50 is preferably integral with the side wall 160. The side wall 160 of the main body 42 has substantially the same external diameter as the side wall 102 of the upper base member 40. The base 164 is convex in shape, and may be described generally as having an inverted saddle-shape. An aperture 166 is formed in the base 164 for allowing the cable 110 to extend from the base 164 of the main body 42. Two pairs of stop members 168 extend upwardly (as illustrated in Figure 8) from the periphery of base 164. Each pair of stop members 168 is located along a line extending in a direction substantially parallel to the axis X. For example, one of the pairs of stop members 168 is located along line D-D illustrated in Figure 10(a).

A convex tilt plate 170 is connected to the base 164 of the main body 42. The tilt plate 170 is located within the recess of the main body 42, and has a curvature which is substantially the same as that of the base 164 of the main body 42. Each of the stop members 168 protrudes through a respective one of a plurality of apertures 172 located about the periphery of the tilt plate 170. The tilt plate 170 is shaped to define a pair of convex races 174 for engaging the rolling elements 128 of the upper base member 40. Each race 174 extends in a direction substantially parallel to the axis X, and is arranged

to receive the rolling elements 128 of a respective pair of the support members 120, as illustrated in Figure 9(c).

The tilt plate 170 also comprises a plurality of runners, each of which is arranged to be located at least partially beneath a respective rail of the upper base member 40 and thus co-operate with that rail to retain the main body 42 on the upper base member 40 and to guide the movement of the main body 42 relative to the upper base member 40. Thus, each of the runners extends in a direction substantially parallel to the axis X. For example, one of the runners lies along line D-D indicated in Figure 10(a). In this embodiment, the plurality of runners comprises a pair of relatively long, inner runners 180 located between a pair of relatively short, outer runners 182. With reference also to Figures 9(b) and 10(b), each of the inner runners 180 has a cross-section in the form of an inverted L-shape, and comprises a substantially vertical wall 184 and a curved flange 186 which protrudes orthogonally and inwardly from part of the top of the wall 184. The curvature of the curved flange 186 of each inner runner 180 is substantially the same as the curvature of the curved flange 146 of each inner rail 140. Each of the outer runners 182 also has a cross-section in the form of an inverted L-shape, and comprises a substantially vertical wall 188 and a curved flange 190 which extends along the length of the wall 188, and which protrudes orthogonally and inwardly from the top of the wall 188. Again, the curvature of the curved flange 190 of each outer runner 182 is substantially the same as the curvature of the curved flange 150 of each outer rail 142. The tilt plate 170 further comprises an aperture 192 for receiving the cable 110.

To connect the main body 42 to the upper base member 40, the tilt plate 170 is inverted from the orientation illustrated in Figures 7 and 8, and the races 174 of the tilt plate located directly behind and in line with the support members 120 of the upper base member 40. The cable 110 extending through the aperture 166 of the main body 42 may be threaded through the apertures 108, 192 in the tilt plate 170 and the upper base member 40 respectively for subsequent connection to the controller 44, as illustrated in Figure 3. The tilt plate 170 is then slid over the upper base member 40 so that the rolling elements 128 engage the races 174, as illustrated in Figures 9(b) and 9(c), the

curved flange 190 of each outer runner 182 is located beneath the curved flange 150 of a respective outer rail 142, as illustrated in Figures 9(b) and 10(b), and the curved flange 186 of each inner runner 180 is located beneath the curved flange 146 of a respective inner rail 140, as illustrated in Figures 9(b), 10(b) and 10(c).

5

With the tilt plate 170 positioned centrally on the upper base member 40, the main body 42 is lowered on to the tilt plate 170 so that the stop members 168 are located within the apertures 172 of the tilt plate 170, and the tilt plate 170 is housed within the recess of the main body 42. The upper base member 40 and the main body 42 are then inverted,

10

and the base member 40 displaced along the direction of the axis X to reveal a first plurality of apertures 194a located on the tilt plate 170. Each of these apertures 194a is aligned with a tubular protrusion 196a on the base 164 of the main body 42. A self-tapping screw is screwed into each of the apertures 194a to enter the underlying protrusion 196a, thereby partially connecting the tilt plate 170 to the main body 42.

15

The upper base member 40 is then displaced in the reverse direction to reveal a second plurality of apertures 194b located on the tilt plate 170. Each of these apertures 194b is also aligned with a tubular protrusion 196b on the base 164 of the main body 42. A self-tapping screw is screwed into each of the apertures 194b to enter the underlying protrusion 196b to complete the connection of the tilt plate 170 to the main body 42.

20

When the main body 42 is attached to the base and the bottom surface 43 of the lower base member 38 positioned on a support surface, the main body 42 is supported by the rolling elements 128 of the support members 120. The resilient elements 130 of the support members 120 urge the rolling elements 128 away from the closed lower ends

25

126 of the support members 120 by a distance which is sufficient to inhibit scraping of the upper surfaces of the upper base member 40 when the main body 42 is tilted. For example, as illustrated in each of Figures 9(b), 9(c), 10(b) and 10(c) the lower end 162 of the main body 42 is urged away from the upper surface 104 of the upper base member 40 to prevent contact therebetween when the main body 42 is tilted.

30

Furthermore, the action of the resilient elements 130 urges the concave upper surfaces

of the curved flanges 186, 190 of the runners against the convex lower surfaces of the curved flanges 146, 150 of the rails.

To tilt the main body 42 relative to the base, the user slides the main body 42 in a
5 direction parallel to the axis X to move the main body 42 towards one of the fully tilted
positions illustrated in Figures 5(b) and 5(c), causing the rolling elements 128 to move
along the races 174. Once the main body 42 is in the desired position, the user releases
the main body 42, which is retained in the desired position by frictional forces generated
10 through the contact between the concave upper surfaces of the curved flanges 186, 190
of the runners and the convex lower surfaces of the curved flanges 146, 150 of the rails
acting to resist the movement under gravity of the main body 42 towards the untilted
position illustrated in Figure 5(a). The fully titled positions of the main body 42 are
defined by the abutment of one of each pair of stop members 168 with a respective inner
15 rail 140.

To operate the fan assembly 10 the user depresses an appropriate one of the buttons 20
on the stand 12, in response to which the controller 44 activates the motor 56 to rotate
the impeller 52. The rotation of the impeller 52 causes a primary air flow to be drawn
into the stand 12 through the air inlets 18. Depending on the speed of the motor 56, the
20 primary air flow may be between 20 and 30 litres per second. The primary air flow
passes sequentially through the impeller housing 64 and the open upper end of the main
body 42 to enter the interior passage 86 of the nozzle 14. Within the nozzle 14, the
primary air flow is divided into two air streams which pass in opposite directions around
the central opening 24 of the nozzle 14. As the air streams pass through the interior
25 passage 86, air enters the mouth 26 of the nozzle 14. The air flow into the mouth 26 is
preferably substantially even about the opening 24 of the nozzle 14. Within each
section of the mouth 26, the flow direction of the portion of the air stream is
substantially reversed. The portion of the air stream is constricted by the tapering
section of the mouth 26 and emitted through the outlet 98.

The primary air flow emitted from the mouth 26 is directed over the Coanda surface 28 of the nozzle 14, causing a secondary air flow to be generated by the entrainment of air from the external environment, specifically from the region around the outlet 98 of the mouth 26 and from around the rear of the nozzle 14. This secondary air flow passes
5 through the central opening 24 of the nozzle 14, where it combines with the primary air flow to produce a total air flow, or air current, projected forward from the nozzle 14. Depending on the speed of the motor 56, the mass flow rate of the air current projected forward from the fan assembly 10 may be up to 400 litres per second, preferably up to 600 litres per second, and the maximum speed of the air current may be in the range
10 from 2.5 to 4 m/s.

The even distribution of the primary air flow along the mouth 26 of the nozzle 14 ensures that the air flow passes evenly over the diffuser surface 30. The diffuser surface 30 causes the mean speed of the air flow to be reduced by moving the air flow through a
15 region of controlled expansion. The relatively shallow angle of the diffuser surface 30 to the central axis X of the opening 24 allows the expansion of the air flow to occur gradually. A harsh or rapid divergence would otherwise cause the air flow to become disrupted, generating vortices in the expansion region. Such vortices can lead to an increase in turbulence and associated noise in the air flow which can be undesirable,
20 particularly in a domestic product such as a fan. The air flow projected forwards beyond the diffuser surface 30 can tend to continue to diverge. The presence of the guide surface 32 extending substantially parallel to the central axis X of the opening 30 further converges the air flow. As a result, the air flow can travel efficiently out from the nozzle 14, enabling the air flow can be experienced rapidly at a distance of several
25 metres from the fan assembly 10.

The invention is not limited to the detailed description given above. Variations will be apparent to the person skilled in the art. For example, the stand 12 may be used in a variety of appliances other than a fan assembly. The movement of the main body 42
30 relative to the base may be motorised, and actuated by the user through depression of one of the buttons 20.

CLAIMS

1. A fan assembly for creating an air current, the fan assembly comprising a stand
5 and an air outlet mounted on the stand for emitting an air flow, the stand comprising a
base and a body tiltable relative to the base from an untilted position to a tilted position,
the body comprising means for creating said air flow, the fan assembly having a centre
of gravity located so that when the base is located on a substantially horizontal support
10 surface, the projection of the centre of gravity on the support surface is within the
footprint of the base when the body is in a fully tilted position.
2. A fan assembly as claimed in claim 1, wherein the centre of gravity of the fan
assembly is located within the body.
- 15 3. A fan assembly as claimed in claim 1 or claim 2, wherein the means for creating
said air flow comprises an impeller and a motor for driving the impeller.
4. A fan assembly as claimed in any of the preceding claims, wherein the
projection of the centre of gravity on the support surface is behind the centre of the base
20 with respect to a forward direction of the fan assembly when the body is in an untilted
position.
5. A fan assembly as claimed in any of the preceding claims, wherein the stand is
substantially cylindrical.
- 25 6. A fan assembly as claimed in any preceding claim, wherein the base has a
substantially circular footprint having a radius r , and a longitudinal axis passing
centrally therethrough, and wherein the centre of gravity of the fan assembly is spaced
by a radial distance of no more than $0.8r$ from the longitudinal axis when the body is in
30 a fully tilted position.

7. A fan assembly as claimed in claim 6, wherein the centre of gravity of the fan assembly is spaced by a radial distance of no more than $0.6r$ from the longitudinal axis when the body is in a fully tilted position.

5 8. A fan assembly as claimed in claim 6 or claim 7, wherein the centre of gravity of the fan assembly is spaced by a radial distance of no more than $0.4r$ from the longitudinal axis when the body is in a fully tilted position.

9. A fan assembly as claimed in any of the preceding claims, comprising
10 interlocking means for retaining the body on the base.

10. A fan assembly as claimed in claim 9, wherein the interlocking means are preferably enclosed by the outer surfaces of the base and the body when the body is in the untilted position.

15

11. A fan assembly as claimed in claim 9 or claim 10, comprising means for urging the interlocking means together to resist movement of the body from the tilted position.

12. A fan assembly as claimed in any of claims 9 to 11, wherein the interlocking
20 means comprises a first plurality of locking members located on the base, and a second plurality of locking members located on the body and which are retained by the first plurality of locking members.

13. A fan assembly as claimed in any of claims 9 to 12, wherein the interlocking
25 means comprise a first plurality of interlocking flanges connected to the base, and a second plurality of interlocking flanges connected to the body.

14. A fan assembly as claimed in claim 13, wherein the interlocking flanges are curved.

30

15. A fan assembly as claimed in any of the preceding claims, wherein the stand comprises means for inhibiting the movement of the body relative to the base beyond a fully tilted position.

5 16. A fan assembly as claimed in claim 15, wherein the movement inhibiting means comprises a stop member depending from the body for engaging part of the base when the body is in a fully tilted position.

10 17. A fan assembly as claimed in any of the preceding claims, wherein the base of the stand comprises control means for controlling the fan assembly.

15 18. A fan assembly as claimed in any of the preceding claims, wherein the air outlet comprises a nozzle mounted on the stand, the nozzle comprising a mouth for emitting the air flow, the nozzle extending about an opening through which air from outside the nozzle is drawn by the air flow emitted from the mouth.

19. A fan assembly as claimed in claim 18, wherein the nozzle comprises a Coanda surface located adjacent the mouth and over which the mouth is arranged to direct the air flow emitted therefrom.

20

20. A fan assembly substantially as herein described with reference to the accompanying drawings.

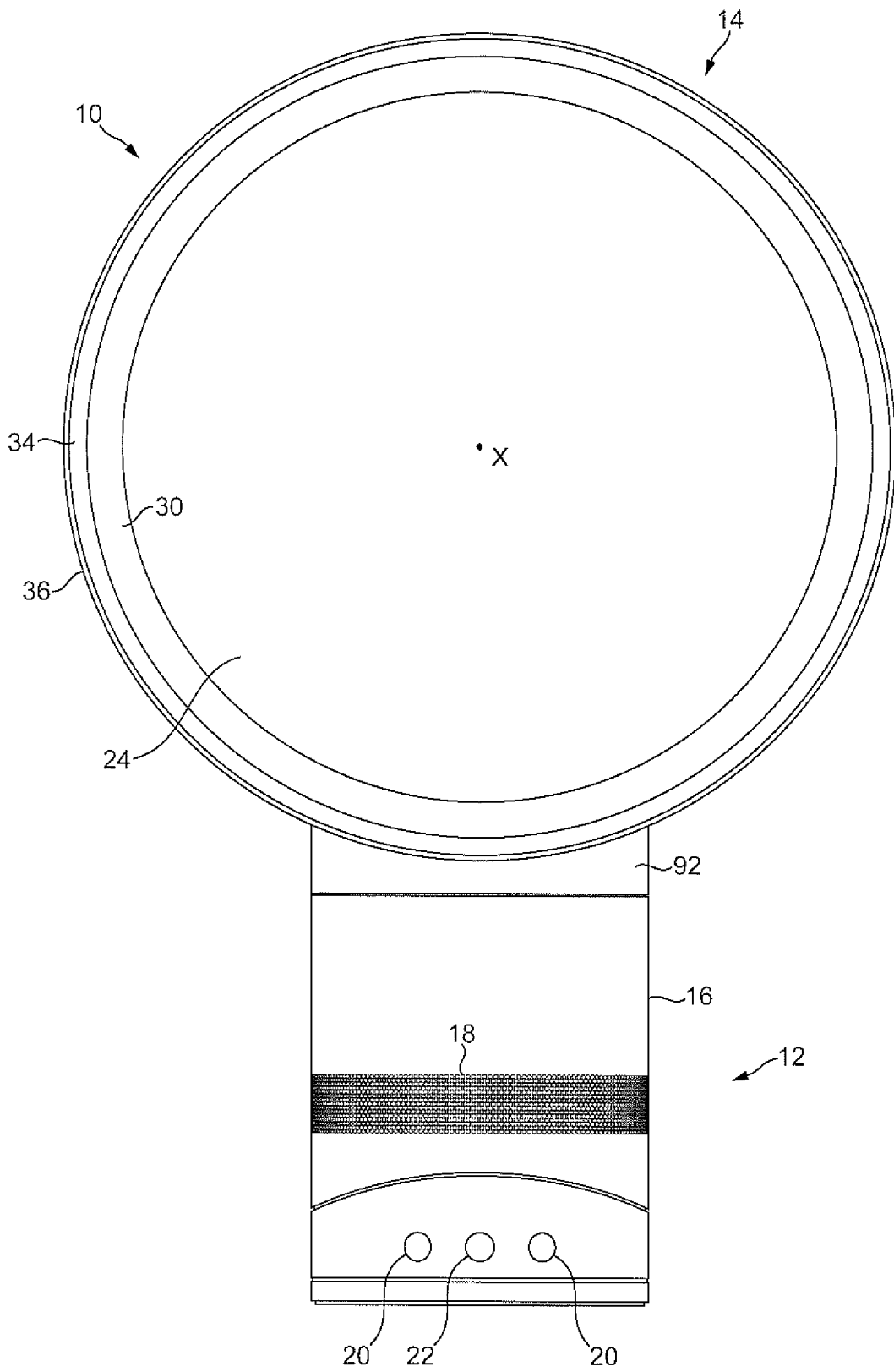

FIG. 1

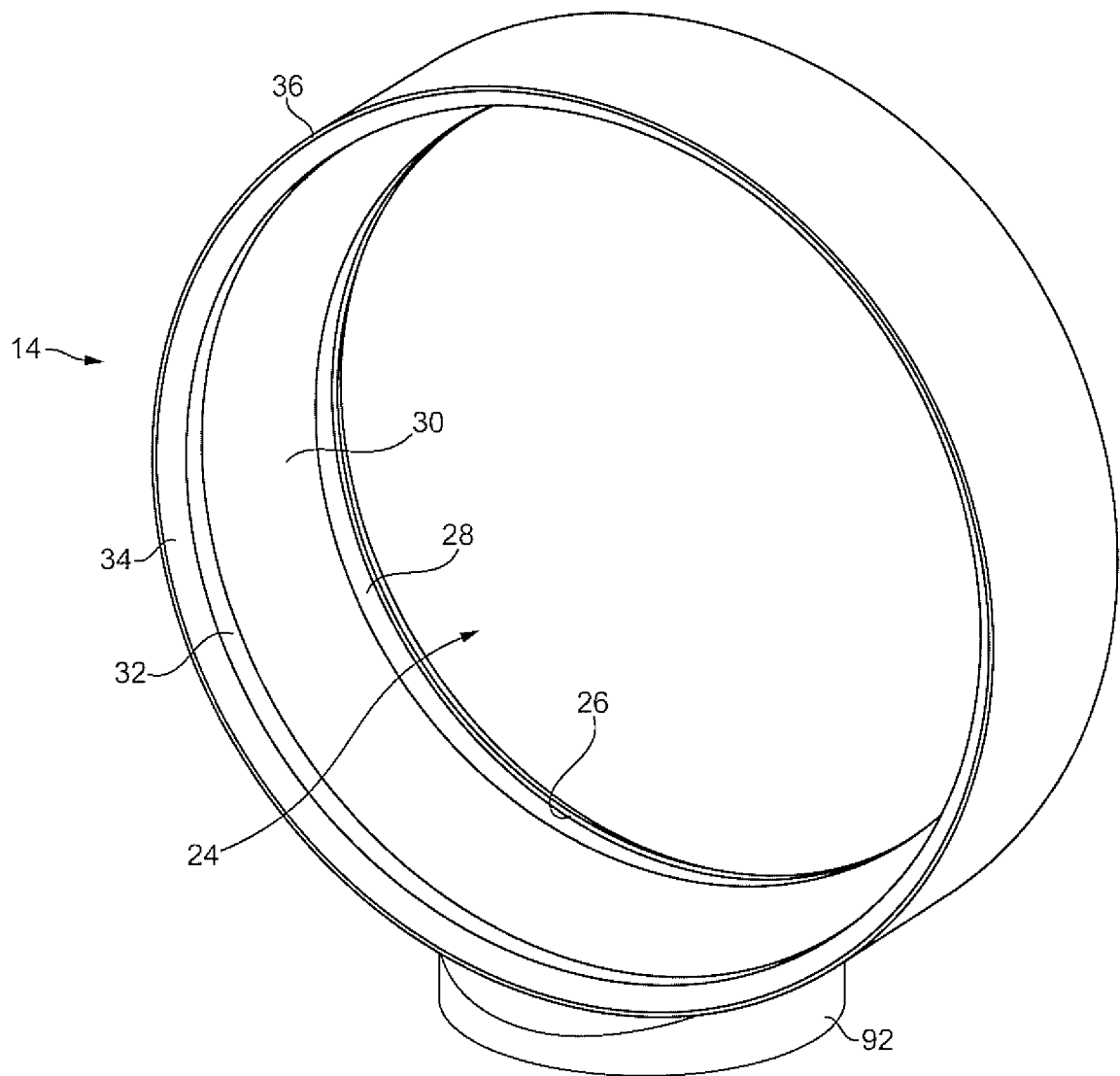

FIG. 2

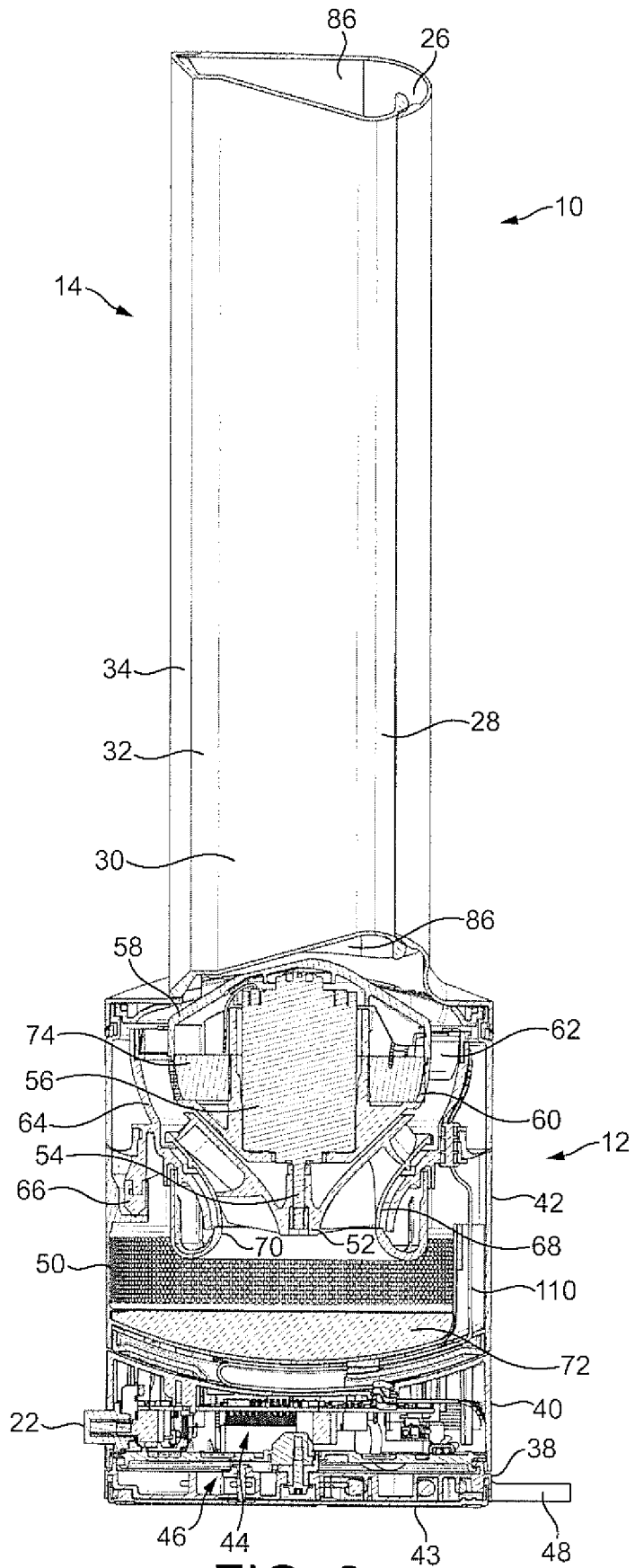

FIG. 3

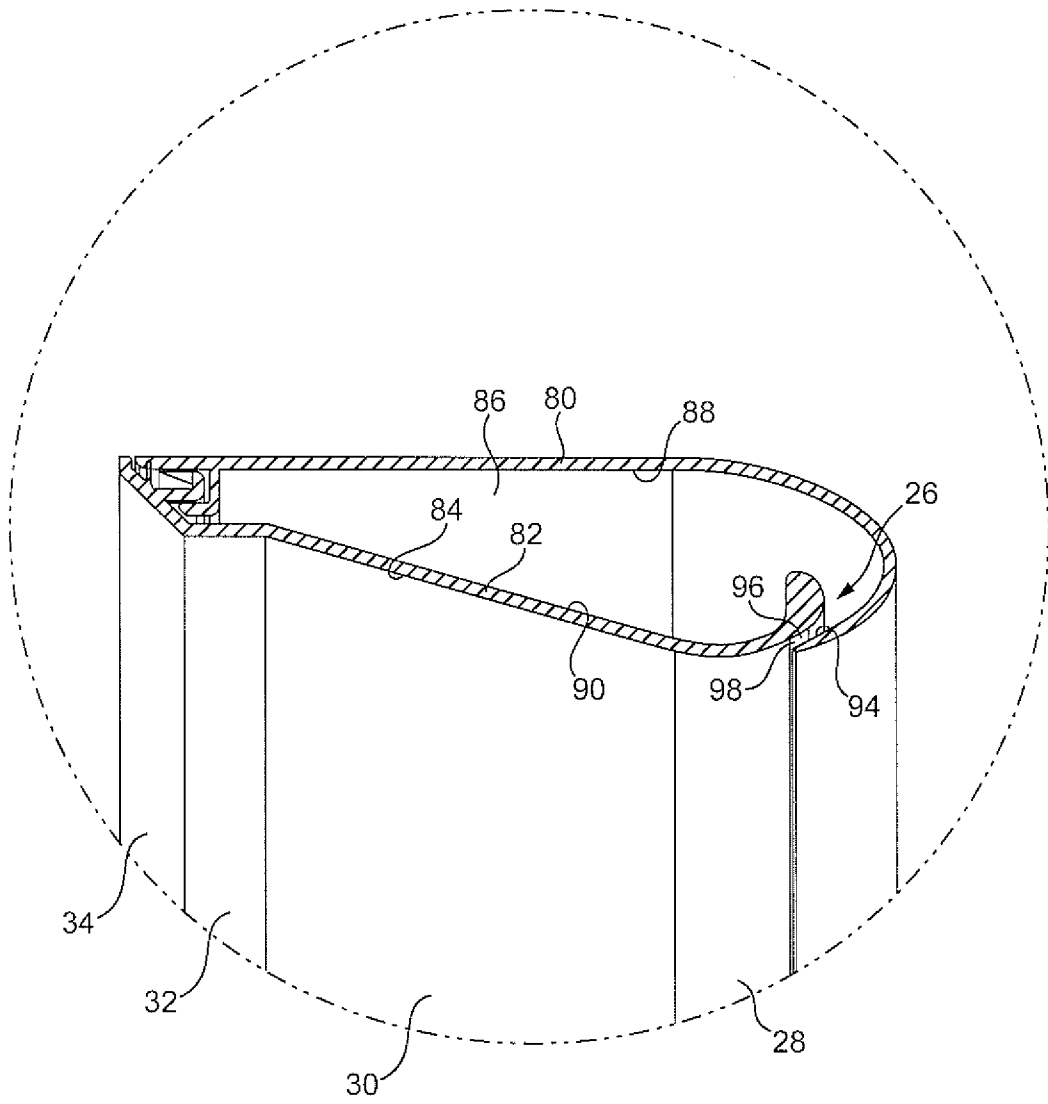

FIG. 4

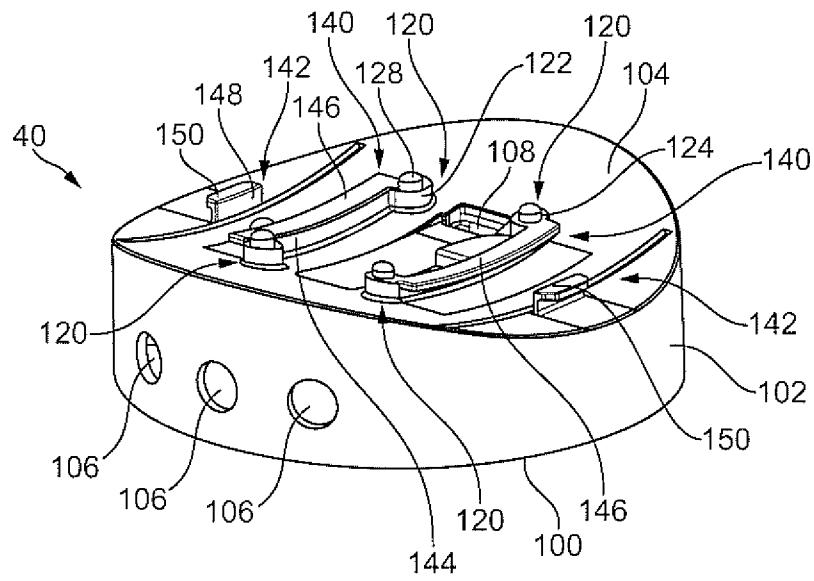

FIG. 6

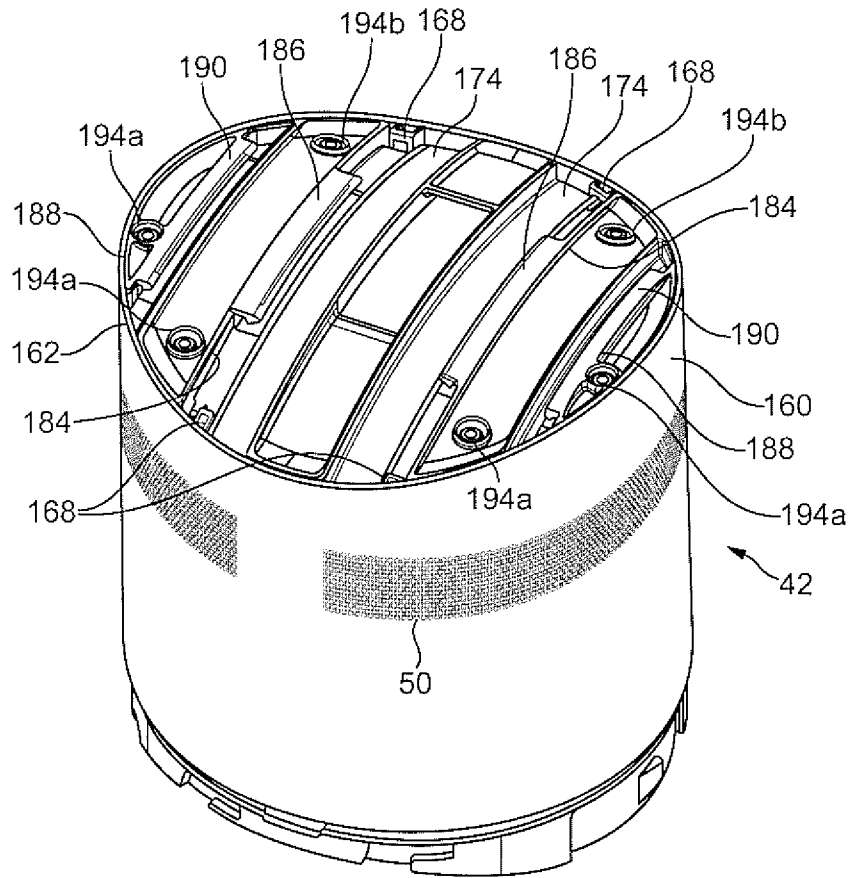

FIG. 7

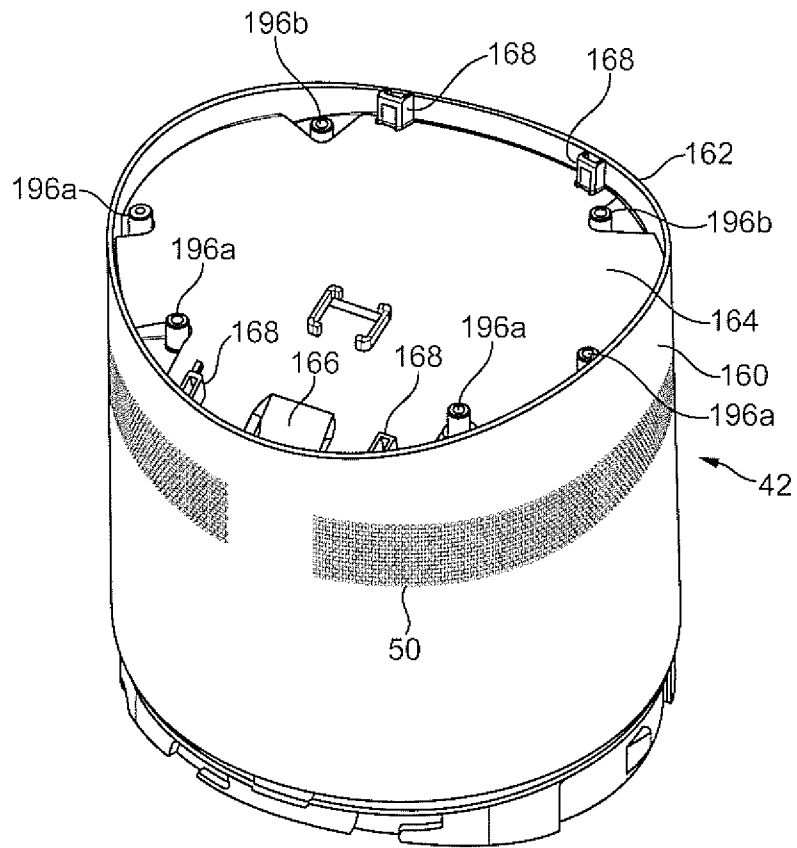
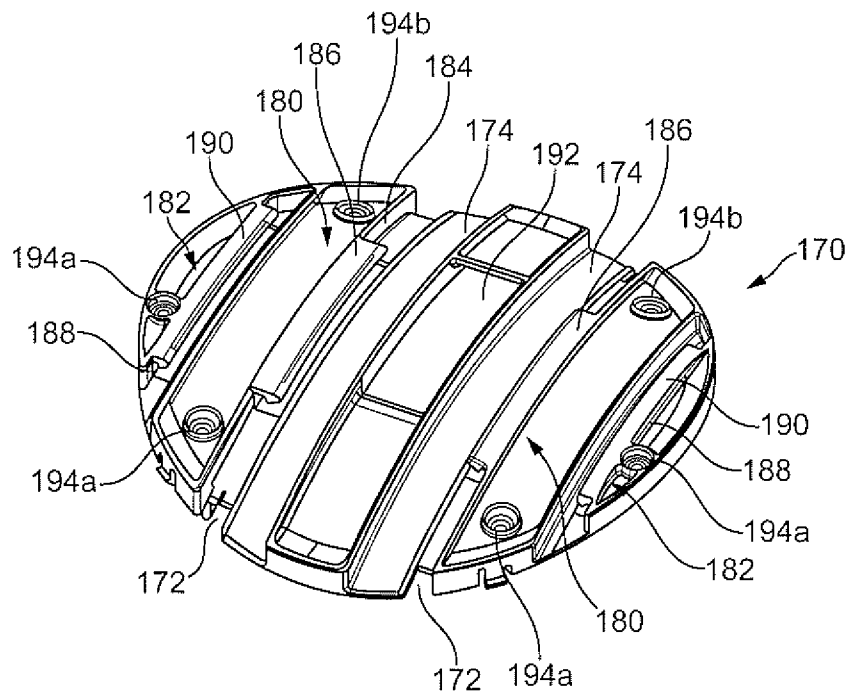

FIG. 8

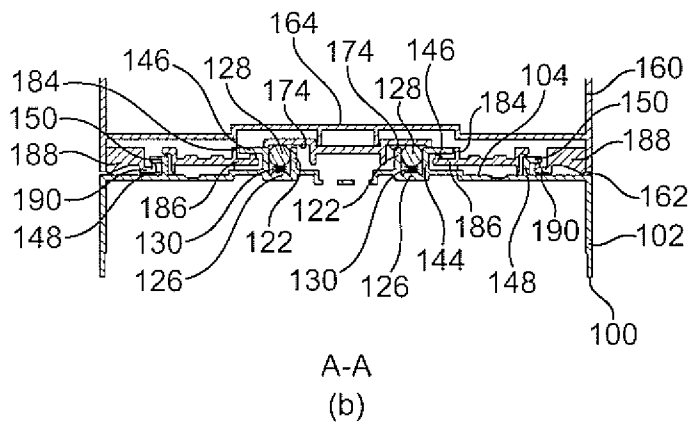
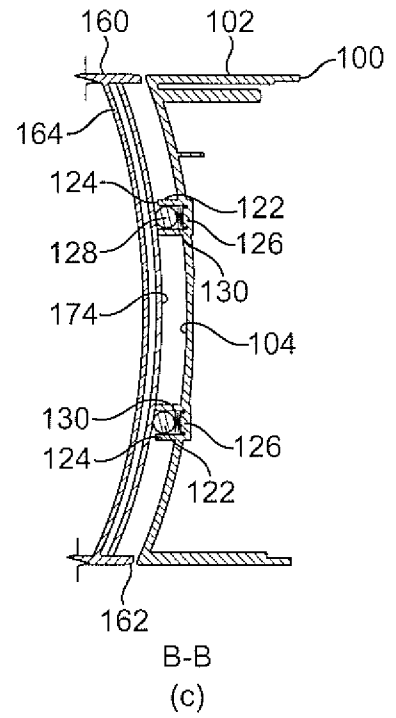
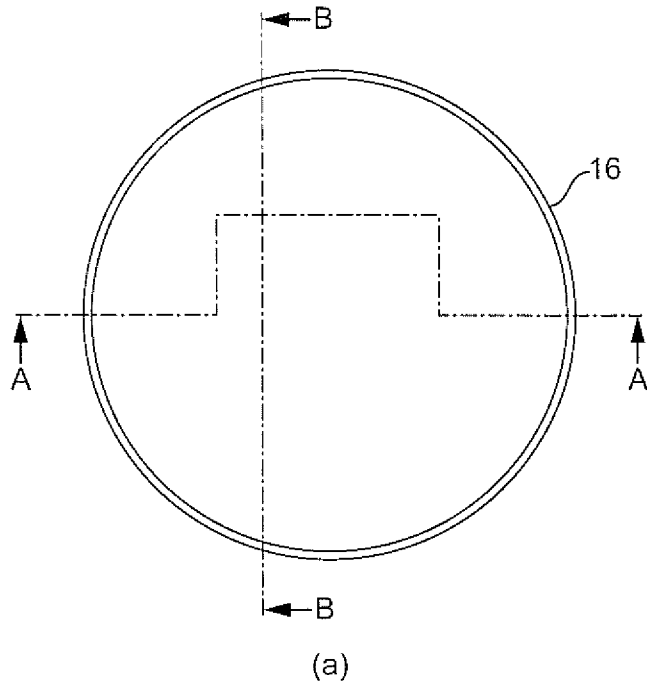

FIG. 9

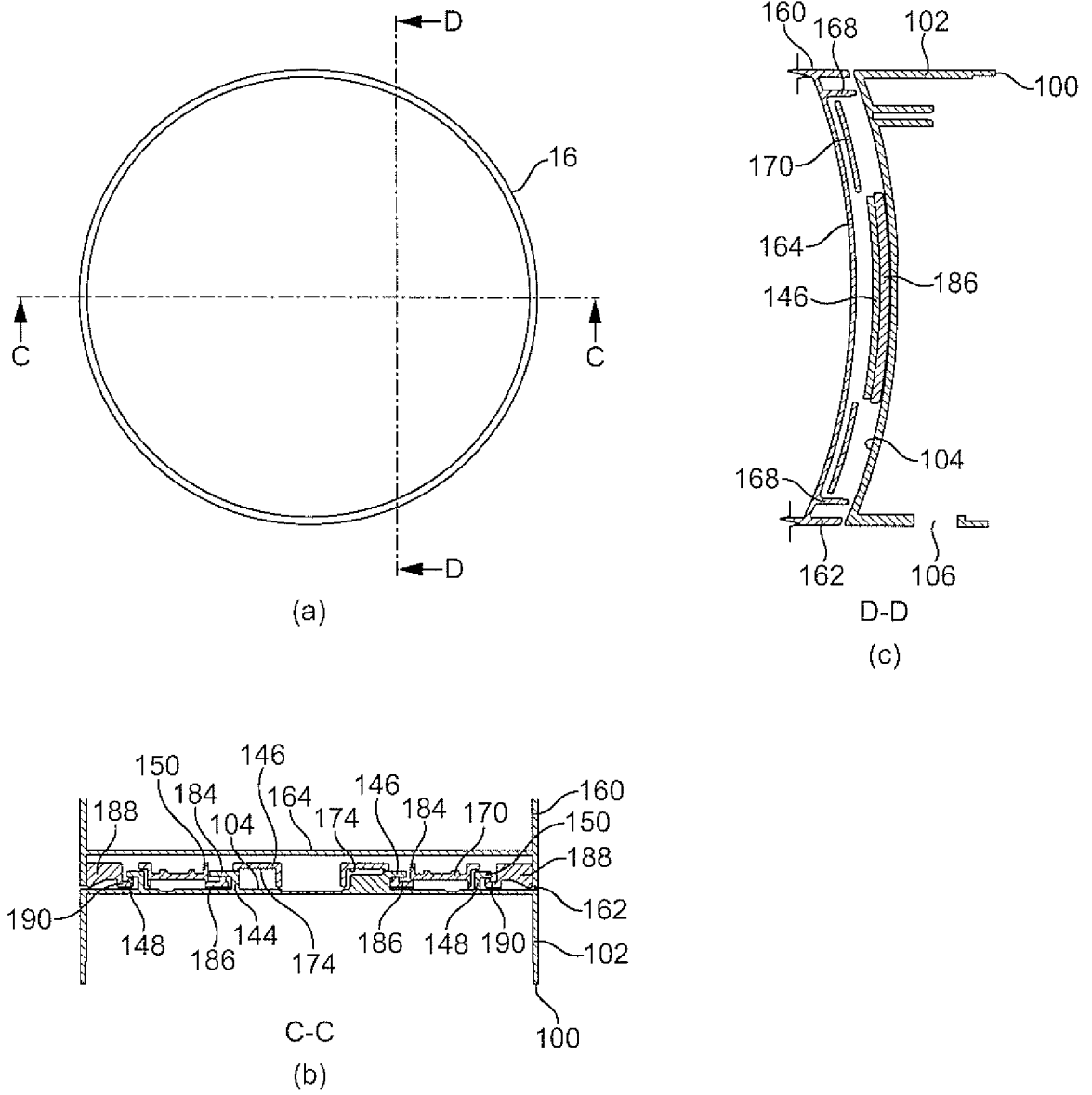

FIG. 10

INTERNATIONAL SEARCH REPORT

International application No
PCT/GB2010/050268

A. CLASSIFICATION OF SUBJECT MATTER

INV. F04D25/10 F04F5/16 F04F5/46
ADD.

According to International Patent Classification (IPC) or to both national classification and IPC

B. FIELDS SEARCHED

Minimum documentation searched (classification system followed by classification symbols)

F04D F04F

Documentation searched other than minimum documentation to the extent that such documents are included in the fields searched

Electronic data base consulted during the international search (name of data base and, where practical, search terms used)

EPO-Internal, PAJ, WPI Data

C. DOCUMENTS CONSIDERED TO BE RELEVANT

Category*	Citation of document, with indication, where appropriate, of the relevant passages	Relevant to claim No.
X	GB 1 278 606 A (OBERLIND VEB ELEKTROINSTALL [DE]) 21 June 1972 (1972-06-21)	1-3,9,12
Y	page 1, line 85 - page 2, line 8; figure 1	18,19
X	US 2 510 132 A (HACKLEY MORRISON) 6 June 1950 (1950-06-06) column 2, line 1.- line 49; figure 2	1-3,5-12
X	CH 346 643 A (TATEISHI ARTHUR K [CA]) 31 May 1960 (1960-05-31) page 2, line 102 - page 3, line 47; figures 1-3,11	1-3,9, 11,12
	----- -/--	

Further documents are listed in the continuation of Box C.

See patent family annex.

* Special categories of cited documents :

- "A" document defining the general state of the art which is not considered to be of particular relevance
- "E" earlier document but published on or after the international filing date
- "L" document which may throw doubts on priority claim(s) or which is cited to establish the publication date of another citation or other special reason (as specified)
- "O" document referring to an oral disclosure, use, exhibition or other means
- "P" document published prior to the international filing date but later than the priority date claimed

- "T" later document published after the international filing date or priority date and not in conflict with the application but cited to understand the principle or theory underlying the invention
- "X" document of particular relevance; the claimed invention cannot be considered novel or cannot be considered to involve an inventive step when the document is taken alone
- "Y" document of particular relevance; the claimed invention cannot be considered to involve an inventive step when the document is combined with one or more other such documents, such combination being obvious to a person skilled in the art.
- "&" document member of the same patent family

Date of the actual completion of the international search

22 April 2010

Date of mailing of the international search report

18/05/2010

Name and mailing address of the ISA/

European Patent Office, P.B. 5818 Patentlaan 2
NL - 2280 HV Rijswijk
Tel. (+31-70) 340-2040,
Fax: (+31-70) 340-3016

Authorized officer

Di Giorgio, F

INTERNATIONAL SEARCH REPORT

International application No
PCT/GB2010/050268

C(Continuation). DOCUMENTS CONSIDERED TO BE RELEVANT		
Category*	Citation of document, with indication, where appropriate, of the relevant passages	Relevant to claim No.
A	GB 633 273 A (ALBERT RICHARD PONTING) 12 December 1949 (1949-12-12) page 5, line 37 - page 6, line 14; figures 1,2 page 6, line 120 - page 7, line 27; figure 5 -----	1-3, 5-10,12, 15-17
Y	JP 56 167897 A (TOKYO SHIBAURA ELECTRIC CO) 23 December 1981 (1981-12-23)	18,19
A	abstract; figures 1-2 -----	1

INTERNATIONAL SEARCH REPORT

Information on patent family members

International application No
PCT/GB2010/050268

Patent document cited in search report		Publication date	Patent family member(s)	Publication date
GB 1278606	A	21-06-1972	NONE	
US 2510132	A	06-06-1950	NONE	
CH 346643	A	31-05-1960	NONE	
GB 633273	A	12-12-1949	NONE	
JP 56167897	A	23-12-1981	NONE	